

Philips - TMC

PHILIPS TELECOMMUNICATIONS MANUFACTURING COMPANY LIMITED

FMI680

VHF RADIOTELEPHONE

ISSUE I

PUBLICATION NO. 450-782-235

FIRST ISSUE NOVEMBER 1970

REPRINTED MAY 1972

This handbook is for the maintenance of telecommunication equipment. The performance figures quoted are typical and are subject to normal manufacturing and service tolerances. The right is reserved to alter the equipment or specifications in the light of future technical development.

Radio Communication Division,
Head Office and Factory,
Clarendon Road, Clayton,
Melbourne, Victoria, Australia.

Postal Address,
P.O. Box 105, Clayton,
Victoria, Australia 3168.

Telex AA 31881
Telephone 544 0366
Telegrams "Philtelcom" Melbourne.

Contents

GENERAL		Page
Title Page		1
Agents, Amendments and Abbreviations		2
List of Contents		3
Introduction		4
Data Summary		5
Receiver Circuit Description		6
Transmitter Circuit Description		8
Netting		10
Installation		11
Aerial Cutting		12
A BAND (70–85 MHz)		
Transmitter Alignment and Test Procedure		13
Receiver Alignment and Test Procedure		17
Parts Lists		21
A Band Circuit Diagram	450–782–237	33
C BAND (148–174 MHz)		
Transmitter Alignment and Test Procedure		35
Receiver Alignment and Test Procedure		39
Parts Lists		43
C Band Circuit Diagram	450–782–236	55

Type FM1680

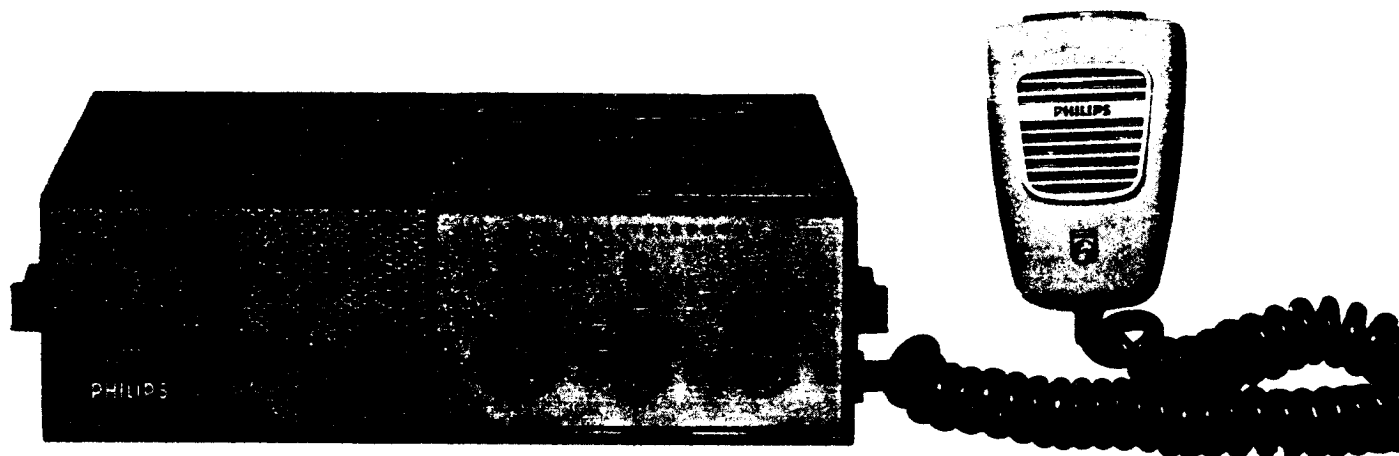

The eight basic models of the FM1680 Mobile Radiotelephone are designated as follows:

A Band (70-85 MHz)

FM1680A/10N	10 watt transmitter output power, (25-30 kHz Channel Spacing)
FM1680A/10NW	10 watt transmitter output power, (50-60 kHz Channel Spacing)
FM1680A/25N	25 watt transmitter output power, (25-30 kHz Channel Spacing)
FM1680A/25NW	25 watt transmitter output power, (50-60 kHz Channel Spacing)

C Band (148-174 MHz)

FM1680C/10N	10 watt transmitter output power, (25-30 kHz Channel Spacing)
FM1680C/10NW	10 watt transmitter output power, (50-60 kHz Channel Spacing)
FM1680C/25N	25 watt transmitter output power, (25-30 kHz Channel Spacing)
FM1680C/25NW	25 watt transmitter output power, (50-60 kHz Channel Spacing)

INTRODUCTION

The FM1680 Mobile Radiotelephone is a solid state, frequency-modulated receiver-transmitter, designed for simplex operation in the VHF band of 70-85 MHz (A Band) or 148-174 MHz (C Band). A multi-channel version, providing up to six channels of operation, and a single channel version are available. Channel spacing can be either 25-30 kHz (Narrow) or 50-60 kHz (Wide). The crystal-controlled transmitter can be supplied to provide an output power of either 10 or 25 watts. The double super-heterodyne receiver provides an audio output of approximately 2 watts. Automatic muting operates in the absence of a signal. The equipment operates on a nominal 12 volt d.c. supply and is protected from aerial mismatch, short circuit, and supply polarity reversal.

Data Summary

GENERAL

Dimensions	:	2¼ in x 9 in x 9½ in (7 cms x 23 cms x 24 cms)
Weight	:	6.5 lbs (2.95 kgm)
Operating Voltage	:	Nominal 12V d.c. : Test at 13.8V d.c.
Current Consumption	:	Receive (no signal) : 70 mA Transmit (10 watt output) : 1.8A Transmit (25 watt output) : 4.75A

RECEIVER

Frequency Range	:	70–85 MHz (A Band) : 148–174 MHz (C Band)
Circuit	:	Double conversion superheterodyne
Channel Spacing	:	25–30 kHz or 50–60 kHz
Frequency Stability	:	Over temperature range 0°C to +60°C : ±0.0015%
Input Impedance	:	Unbalanced : 50 ohms
Deviation Capability	:	±5 kHz or ±15 kHz
Audio Output	:	At 1 kHz : 2 watts
Audio Distortion	:	With output of 2 watts at 1 kHz : 10%
Sensitivity	:	For 12 dB SINAD : 0.5 µV (p.d.)
Quieting	:	20 dB for 0.5 µV (p.d.)
Muting Level	:	Adjustable from 0.5 µV to approximately 1.5 µV (p.d.)
Signal/Noise Ratio	:	At 1 µV (p.d.), with full deviation at 5 kHz 32 dB, at 15 kHz 40 dB.
Selectivity	:	Receiver IF Response relative to centre frequency: ±25–30 kHz : 90–100 dB ±50–60 kHz : 90–100 dB Spurious and Image Response referred to 1 µV input : better than 80 dB.

TRANSMITTER

Frequency Range	:	70–85 MHz (A Band) : 148–174 MHz (C Band)
Frequency Stability	:	Over temperature range 0°C to +60°C : ±0.002%
Modulation	:	Phase (Angle modulated)
Deviation	:	Controlled by instantaneous slope limiter : ±5 kHz or ±15 kHz
Audio Response	:	From pure phase 300–3000 Hz : +1 dB to –3 dB. Reference +6 dB/octave pre-emphasis curve
Audio Distortion	:	For 66% of maximum deviation at 1 kHz : 5%
Noise Level	:	Relative to full modulation with 1 kHz tone : –50 dB for 25–30 kHz channel spacing
Spurious Radiation	:	0.25 µwatts
Harmonic Radiation	:	0.5 µwatts
Output Impedance	:	Unbalanced : 50 ohms
Power Output	:	10 watts or 25 watts

CRYSTAL INFORMATION

Receiver

Crystal frequency	:	$\frac{f(\text{carrier}) + 10.7}{3} = 26.9 - 31.9 \text{ MHz (A Band)}$ $\frac{f(\text{carrier}) - 10.7}{4} = 34.325 - 40.825 \text{ MHz (C Band)}$
-------------------	---	--

Specification	:	3502–150–0558.2 (A Band) : 2502–150–0555.2 (C Band)
---------------	---	---

Transmitter

Crystal frequency	:	$\frac{f(\text{carrier})}{8} = 8.75 - 10.625 \text{ MHz (A Band)} : 18.5 - 21.75 \text{ MHz (C Band)}$
-------------------	---	--

Specification	:	3502–150–0560.2 (A Band) : 3502–150–0556.2 (C Band)
---------------	---	---

NOTE: When ordering crystals the frequency should be converted from MHz to kHz and given to three decimal places.

Receiver Circuit Description

NOTE: Also refer to circuit diagrams on Pages 33, 55.

1. With the receiver in the activated state, incoming signals from the aerial pass through the harmonic filter and change-over relay contacts RLA/1 on U12 to the RF amplifier on U4.
2. The R.F. amplifier operates in the common emitter mode. Input signals are applied to the input transformer 4L1, 4L2 which is double-tuned and has a protection diode, MR1, across the primary. Signals are amplified by 4TS1 and passed to the first mixer stage, 4TS2, via the individually tuned coupling circuits 4L3, 4L4 and 4L5 which improve the RF signal selectivity.
3. The local oscillator is a Pierce-Colpitts circuit, 5TS1, and the harmonic amplifier, 5TS2, has a double-tuned output coupling, 5L2, 5L3, to enable the correct harmonic to be selected for injection to the first mixer.
4. Connection to the first mixer is made via a twisted wire capacitor. A common base circuit is used for the first mixer with the output selected at 10.7 MHz by the tuned circuit, 4L9, in the collector lead of 4TS2. Impedance matching to the input of the 10.7 MHz crystal filter XL-F is provided by a capacitive impedance division in 4L9.
5. The output of the filter XL-F is applied to the first IF amplifier, 6TS1, where it is amplified to a suitable level and passed to the base of 6TS2, the second mixer.
6. The second local oscillator, 6TS7, is controlled by crystal XL-M at 10.245 MHz and the output is taken from the collector of 6TS7, via 6C31, to the base of 6TS2, the second mixer.
7. The output of the second mixer, at 455 kHz is selected by 6L2, 6C8 in the collector circuit of 6TS2.

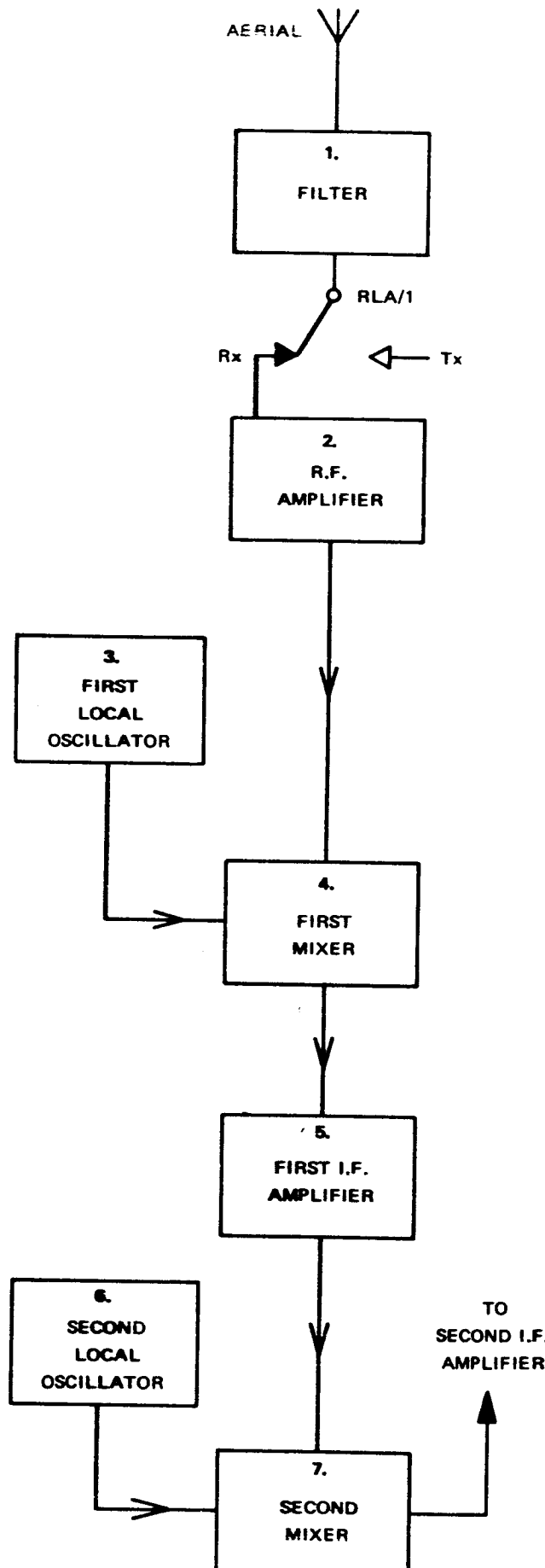

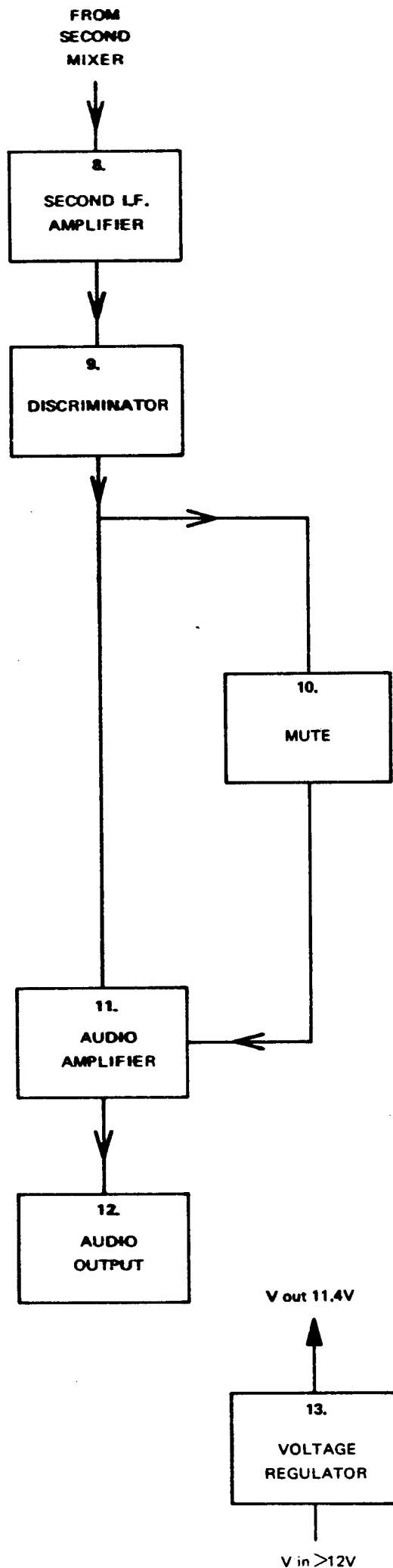

8. Amplification of the 455 kHz signal is provided by the second IF amplifier 6TS3, 6TS4, 6TS5 and 6TS6. All amplitude modulation is removed by the limiting action of diodes MR1 and MR2.

9. The IF frequency is converted to an audio signal in the discriminator which is a modified Foster-Seeley circuit comprising the two tuned circuits 6L4, 6C22 and 6L5, 6C24, 6C25. Coupling between the two circuits is provided by 6C23. An RC filter for the audio output of the discriminator is provided by 6R21, 6R22, 6R23, 6C28, 6C29 and 6C30.

10. The audio output of the discriminator is fed via 7C20, 7R27 and 7R7 to a driver amplifier and via 7C1 to a muting circuit on U7. A noise amplifier in the muting circuit consists of 7TS1 with an input filter 7L2, 7C2, 7C19 and an output filter 7L1, 7C5, 7C6. The filters are tuned to accept noise frequencies and reject voice frequencies. When there is no incoming signal, noise from the aerial and receiver front end is amplified by the noise amplifier and detected by diodes MR1 and MR2. The change in d.c. level is applied to the base of 7TS3 which is thereby cut off; consequently 7TS2 is cut off, thus muting the audio output stage. When a signal is present any noise is reduced to a level which is insufficient to operate the switching transistor 7TS3 and the audio amplifier is not muted. As the audio signals are rejected by the noise amplifier no muting action results from an audio input. When the signal is removed the noise level rises and the receiver is again muted. The muting level can be adjusted by 8RV2 which alters the bias of the noise detector diodes and 7TS3. This control is mounted on the front panel.

11. The audio signal is amplified in the audio amplifier and passed to the audio output stage via the volume control 8RV1.

12. An output of approximately 2 watts is provided by the audio output stage 7TS5, 7TS6 and 7TS7.

13. A positive rail of 11.4V is provided by the d.c. voltage regulator.

Transmitter Circuit Description

NOTE: Also refer to circuit diagrams on Pages 33, 55.

1. When the PTT switch is operated the change-over relay RLA is energised; this switches off the receiver and activates the transmitter.
2. The input from the microphone is coupled through 1RV1 and 1C1 to the amplifier stage 1TS1. After amplification the signal is differentiated in the RC coupling circuit, 1R5, 1C4, to obtain an audio response rising with frequency. The amplitude of the differentiated signal is clipped in the limiting circuit 1TS2, 1MR1, 1MR2 and the limiting level is set by 1RV1. Frequency response is restored in the integrator circuit 1TS3, 1C14. If the input signal is large enough to cause heavy limiting, over modulation by the low frequencies is prevented by 1MR3 and 1MR4. The signal bandwidth is restricted to 3 kHz by the LC filter 1C12, 1L1, 1C13 and the input to the phase modulator is adjusted by 1RV2.
3. The frequency of the transmitter oscillator 2TS1 is controlled by crystal XL-T and its associated tuning coil in the channel crystal assembly.
4. The output of the crystal controlled oscillator and the output of the amplifier are applied to the two-stage modulator 2L15, 2L16. The frequency modulated signal is coupled via 2TS2 to the first stage of the frequency multiplier, 2TS3.
5. Three bandpass-coupled doubler stages 2TS3, 2TS4, 2TS5 provide an output at 8 times the crystal frequency.
6. The output of the frequency multiplier is coupled via 2TS6 to the output driver amplifier, 2TS7, the resonant impedance coupling being achieved by utilising the input and output capacitance of the transistors. The output of the driver amplifier is at signal frequency and of sufficient power to drive the output stage.

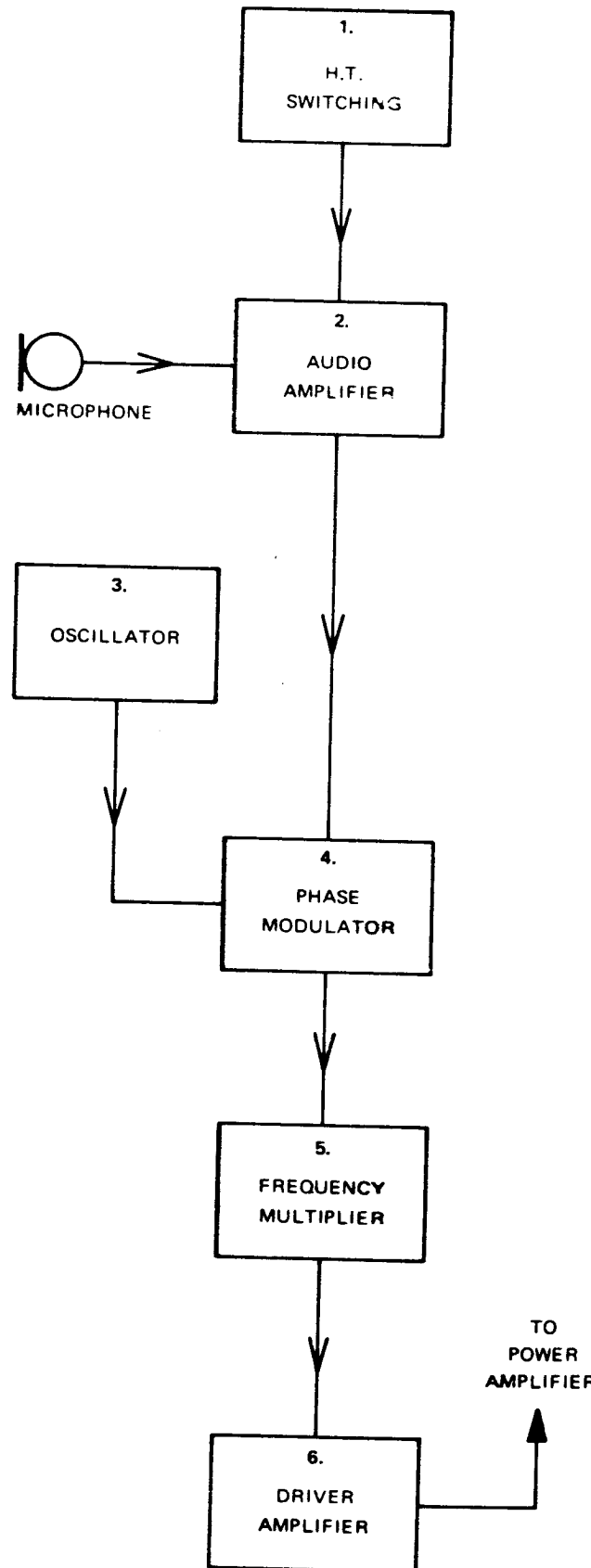

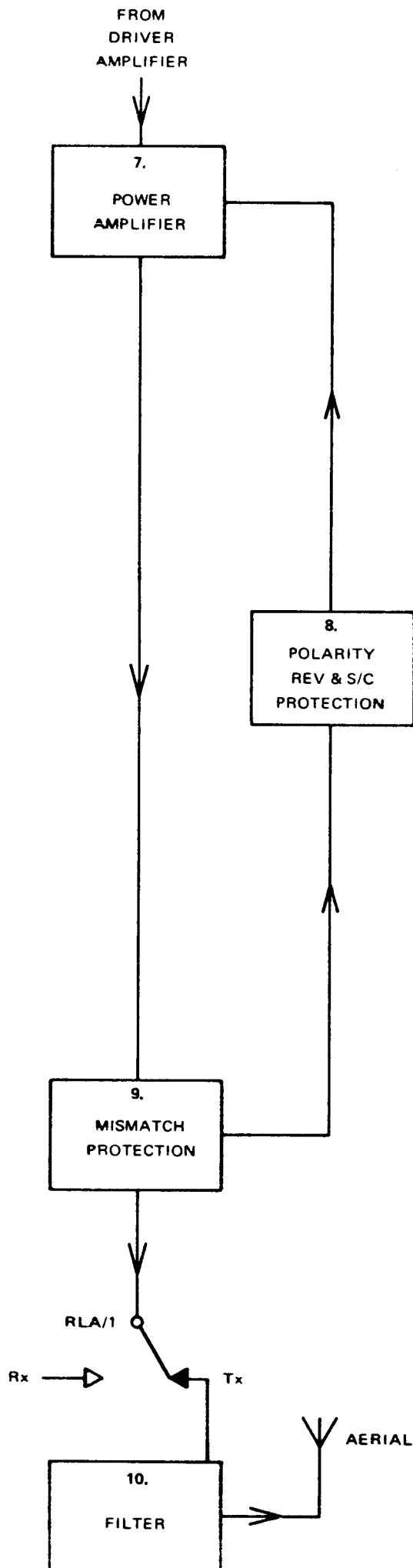

7. The power amplifier stage utilises silicon RF power transistors and provides either 10 or 25 watts output. In the A band circuit the 10 watt unit has one power amplifier stage 3TS2; the 25 watt unit has a driver stage 3TS1 and an output stage 3TS2, 3TS3. In the C band circuit the 10 watt unit has a driver stage 3TS1 and an output stage 3TS2; the 25 watt unit has three stages, a sub-driver 3TS1, a driver amplifier 3TS2 and the output stage 3TS3, 3TS4. Input, interstage and output couplings provide impedance matching. As the gain of the transistors increases at frequencies lower than the operating frequency, each transistor base is loaded with a ferroxcube choke to maintain low frequency stability.

8. A polarity reversal and short circuit protection unit is provided for the final stages of the transmitter. A polarising diode, 13MR1, is connected in series with the supply to the coil of the change-over relay RLA to prevent the transmitter from being keyed by the PTT if the polarity of the supply is reversed.

Current is supplied to the power amplifier stage of the transmitter via 13TS1. Potentiometer 13RV1 can be adjusted to ensure that sufficient current is available under normal transmit conditions and that a graded reduction of current is made under short circuit or overload conditions. For the 10 watt amplifier, the voltage at the base of 13TS1 and 13TS2 is set by the potential divider 13R1, 13R2, to give correct current flow under normal conditions. If the power amplifier stage is affected by an overload or short circuit, the collector of 13TS1 is driven negative and the increased potential across 13R1, 13R2 is applied to 13TS1 and 13TS2. This reduces the amount of current that can be passed to the power amplifier via 13TS1.

For the 25 watt amplifier, the voltage at the base of 13TS1 and 13TS2 is set by 13R1 and 13MR2. When an overload or short circuit occurs the collector of 13TS1 is driven negative, the polarity of 13MR2 is reversed and 13TS1 is switched via 13TS2 to pass a very low current, thus protecting the power amplifier stage.

9. The output signal passes to the aerial mismatch protection circuit which contains a directional coupler and a d.c. reference circuit. Diode MR1 acts as an RF detector and 14TS1 controls the supply to the power amplifier, via 13TS2, in the short circuit and polarity reversal protection circuit. Aerial mis-tuning, or short circuit or open circuit causes an increase in the standing wave ratio which increases the detected RF level across 14RV1. The change in d.c. level is applied to the base of 14TS1; the output of 14TS1 is applied to the base of 13TS1, which in turn controls the supply to the final amplifier. Potentiometer 14RV1 controls the RF level at which the supply to the final amplifier is reduced. The bias to 14MR1 is set by 14R1 and 14R3; capacitors 14C1 and 14C2 are ripple filters.

10. The output from the mismatch protection unit is fed through relay contact RLA/1 and the harmonic filter to the aerial.

Netting

Before the radiotelephone is installed it is essential that the frequency control crystal circuits of the transmitter and receiver are adjusted for optimum performance by trimming the netting coils as follows:

Test Equipment

- (a) Adjacent PMG frequency measuring station, or frequency meter – Gertsch FM3 or similar.
- (b) Aerial or dummy load.
- (c) 455 kHz signal generator – Philips PM 5300 or similar.
- (d) Multimeter – AVO 8

Transmitter

1. If a PMG frequency measuring station is available connect the aerial to the transmitter, switch on and measure the carrier frequency. Select each channel in turn and adjust the appropriate netting coils to correct any frequency error.
2. Alternatively, connect the frequency meter and dummy load to the transmitter, switch on and adjust the netting coils for each channel to correct any frequency error.

Receiver

1. Connect the 455 kHz signal generator, (set to $> 100 \mu V$) to the input of the IF card, U6. Connect the +ve lead of the AVO 8 (50 μA) to TP3 on U6 and the -ve lead to the negative line.
2. Check that AVO 8 reading is zero.
3. Disconnect the 455 kHz signal generator and connect the Gertsch FM3 frequency meter to the aerial input.
4. With the correct frequency injected into the receiver, select each channel in turn and adjust the appropriate netting coils to obtain a reading of zero on the AVO 8.

Installation

Mounting

A mounting kit (451-782-016) comprising mounting tray, microphone bracket, battery cables, all necessary nuts and bolts, and complete installation instructions is supplied with each radiotelephone. The unit can be fitted above or below the mounting tray and is usually located beneath the dash board of the vehicle. A free flow of air must be available around the unit to provide adequate ventilation and heat dissipation.

Electrical Connection

When making electrical connections to the radiotelephone it is essential that the RED battery lead is connected to the positive terminal of the battery. As the d.c. supply is isolated from the outer frame the unit can be installed in either positive or negative earth vehicle systems.

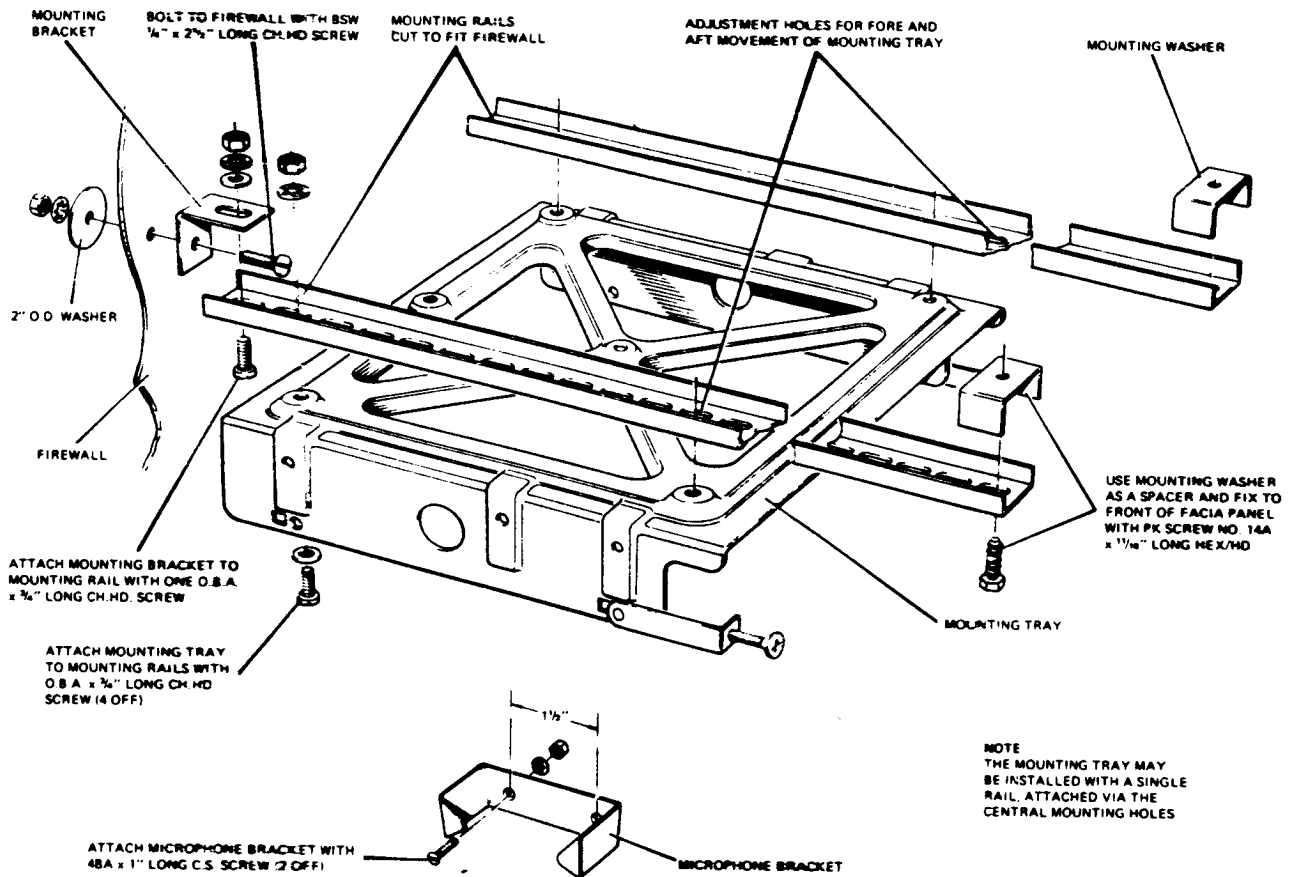

INSTALLATION OF MOUNTING TRAY AND MICROPHONE BRACKET
MOUNTING KIT 451 782-016

Aerial Cutting

PROCEDURE

A whip aerial kit and complete installation instructions are supplied with each radiotelephone. When installed, the whip element must be cut for the lowest VSWR of the operating frequency. Carry out either of the following procedures:

- (a) Connect a V.S.W.R. meter between the radiotelephone and the aerial. Reduce the length of the aerial by $\frac{1}{8}$ " at a time until the lowest VSWR reading is obtained.
- (b) Use the monitor point on the mismatch protection unit and proceed as follows:
 1. Remove the bottom cover of the unit case and connect the +ve lead of the AVO 8 (2.5V d.c.) to the monitor point on the aerial mismatch protection unit. Connect the -ve lead of the AVO 8 to the earth braid.
 2. Operate the PTT and note the reading on the AVO 8 – approximately 0.5V to 0.6V.
 3. Reduce the length of the aerial by $\frac{1}{8}$ " at a time until the AVO 8 reading is approximately 0.35V to 0.4V when the PTT is operated.
 4. When two consecutive checks show no further reduction in the AVO 8 reading, the minimum VSWR has been reached.
 5. Check that 14C5 is set to give minimum AVO 8 reading.
 6. Remove AVO 8 and refit bottom cover to unit.

A BAND (70-85MHz)

Transmitter Alignment and Test Procedure

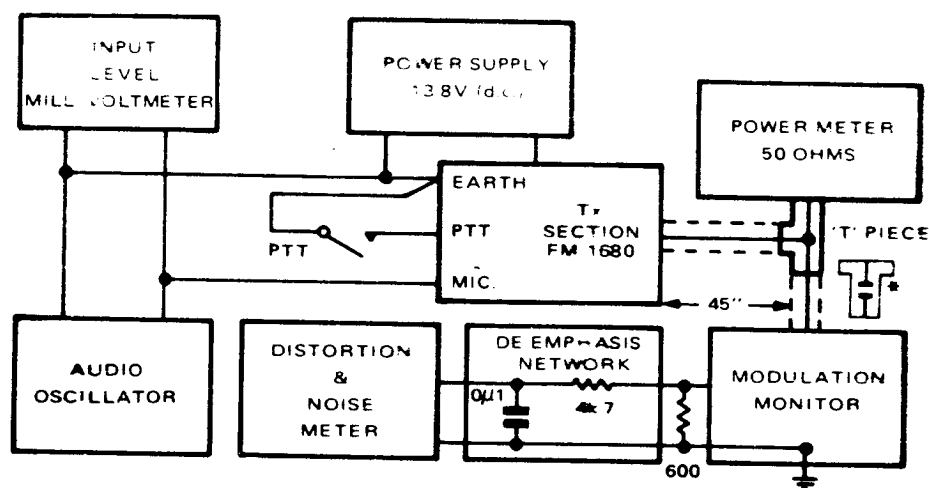

Figure 1

Test Equipment

Equipment having similar characteristics to the items listed below may be used.

- (a) Hum-free Power Supply to give 13.8V d.c. minimum, 5A rating.
- (b) Multimeter — AVO 8
- (c) R.F. Power Meter (50 ohms) — Bird Terminal 612
- (d) Modulation Monitor — Airmec 210A
- (e) Audio Oscillator — Wayne Kerr
- (f) Distortion and Noise Meter — AWA
- (g) VTVM — Philips GM 6009
- (h) De-emphasis Network (4k7 + 0.1μ)
- (j) Mismatch piece (39 pF 10W; 27 pF 25W) *
- (k) Resistors — 3 ohm 40 watt; 6 ohm 40 watt; 220 ohm 1 watt.

NOTE: All component references are prefixed by the number of the board on which the components are mounted e.g. 2C4 refers to capacitor C4 on board U2.

Preparation

1. Set up the equipment as shown in Figure 1.
2. Set 14RV1 fully anti-clockwise.
3. Ensure that the voltage regulator output (U9 pin 3) is within 11.3V to 11.9V.

Polarity Reversal and Short Circuit Protection (U13)

Remove the transmitter crystal to prevent drive to the PA stage. Set 13RV1 to maximum resistance (slide towards rear of radiotelephone).

10 Watt Unit

1. Connect the 6 ohm, 40 watt resistor in series with the AVO 8 (10A d.c.) between U13 pin 2 and the honeycomb.
2. Operate the PTT and check that the current reading is $\geq 2A$.
3. Connect the AVO 8 (2.5V d.c.) between the collector and emitter of 13TS1. Check that $V_{ce} \leq 0.2V$.
4. If necessary, reduce the resistance of 13RV1 to obtain the figures in paras. 2 and 3.
5. Connect the 220 ohm, 1 watt resistor between U13 pin 5 and U13 pin 3 (earth). Check that the current measured as in para. 2 above is $< 1A$ and that the voltage measured as in para. 3 above is $\geq 8V$.
6. Remove the load resistors and replace the transmitter crystal.

25 Watt Unit

1. Connect the 3 ohm, 40 watt resistor in series with the AVO 8 (10A d.c.) between U13 pin 2 and the honeycomb.
2. Operate the PTT and check that the current is $\geq 4A$.
3. Connect the AVO 8 (2.5V d.c.) between the collector and emitter of 13TS1. Check that $V_{ce} \leq 0.4V$.
4. If necessary, reduce the resistance of 13RV1 to obtain the figures in paras. 2 and 3.
5. Connect the 220 ohm, 1 watt resistor between U13 pin 5 and U13 pin 3 (earth). Check that the current measured as in para. 2 above is $< 2A$ and that the voltage measured as in para. 3 above is $\geq 8V$.
6. Remove the load resistors and replace the transmitter crystal.

Adjustment of Trimmers

1. With audio off, adjust the following trimmers:

10 Watt Unit

2C10, 2C14, 2C16, 2C18	–	Minimum capacitance
2C22	–	$\frac{1}{2}$ Maximum capacitance
3C5	–	Maximum capacitance
3C8	–	Minimum capacitance

25 Watt Unit

2C10, 2C14, 2C16, 2C18	–	Maximum capacitance
2C22	–	$\frac{1}{2}$ Maximum capacitance
3C6	–	Minimum capacitance
3C11	–	Maximum capacitance
3C13	–	Mid-way

Alignment of the Exciter Board (U2)

1. Connect the AVO 8 (250 μA) +ve to the +11.4V rail. With the AVO 8 -ve lead monitor the following points:
 - 2TP1 – Tune 2L15, 2L16 for maximum reading (app. 110 μA)
 - 2TP2 – Tune 2L17, 2L18 for maximum reading (app. 120 μA)
 - 2TP3 – Tune 2L19 for maximum reading (app. 114 μA)
Tune 2C14 for minimum reading (app. 35 μA)
 - 2TP4 – Tune 2C16 for maximum reading (app. 57 μA – 10 watt)
(app. 70 μA – 25 watt)
Tune 2C18 and then 2C14 and 2C16 for maximum reading (app. 136 μA – 10 watt)
(app. 40 μA – 25 watt)

Alignment of PA Stage (U3)

10 Watt Unit. CAUTION: Do not tune for a power output of more than 11 watts.

1. With the AVO 8 (250 μA) across 3L6, tune 2C10 for maximum reading. Increase capacitance of 2C22 and re-tune 2C10 for maximum reading. Continue until a reading of approximately 52 μA is obtained.
2. Tune 3C5 for maximum output power. Increase the capacitance of 3C8 and re-tune 3C5 for maximum output power. Continue until maximum output power is obtained.
3. Adjust 2C18, 2C10 for maximum reading on AVO 8.
4. If the output power is < 11 watts, increase 2C22 and re-tune 2C10 to obtain 11 watts output.
5. Reduce output power to 10 – 10.5 watts by reducing capacitance of 3C8 and re-tuning 3C5.

25 Watt Unit. CAUTION: Do not tune for a power output of more than 25.5 watts

1. With the AVO 8 (250 μA) across 3R2, tune 2C10 for maximum reading.
2. Tune 3C6 for maximum output power.
3. Tune 3C11 and 3C13 alternately, to obtain maximum output power. Re-peak 2C18 and 2C10.
4. Repeat the tuning procedure to obtain maximum output power.
5. If the output power is < 25 watts, increase capacitance of 2C22 slightly and re-tune 2C10, 3C6, 3C13 and 3C11. Repeat the procedure until the output power is 25 to 25.5 watts.

Modulation

1. Check that the test equipment is connected as shown in Figure 1.
2. With the transmitter on and the correct output power indicated, tune the modulation monitor to the correct frequency, adjust the input level and set for frequency modulation.
3. Set 1RV1 fully clockwise.
4. For maximum deviation set the audio oscillator to 3 kHz \pm 150 Hz, at an input level of 50 mV \pm 5 mV, and adjust 1RV2 to give the following:

Narrow channel separation (N)	–	5 kHz \pm 0.3 kHz deviation
Wide channel separation (NW)	–	15 kHz \pm 0.3 kHz deviation

5. Set the audio oscillator to $1 \text{ kHz} \pm 50 \text{ Hz}$ with an input level of $5 \text{ mV} \pm 0.5 \text{ mV}$ and set 14RV1 to give the following:

Narrow channel separation (N)	–	$3.3 \text{ kHz} \pm 0.1 \text{ kHz}$ deviation
Wide channel separation (NW)	–	$10 \text{ kHz} \pm 0.3 \text{ kHz}$ deviation
6. Recheck para. 4. Deviation should not exceed 5 kHz for N and 15 kHz for NW.
7. Under the conditions set in para. 5 check the following:

Distortion	–	$< 5\%$
Noise	–	More than 50 dB below 3.3 kHz for N More than 50 dB below 10 kHz for NW

Field Test. An alternative method of testing operation and deviation is as follows:

1. Do not connect the audio oscillator, leave the microphone connected.
2. With the transmitter on and the correct output power indicated, tune the modulation monitor to the correct frequency, adjust the input level and set for frequency modulation.
3. With the PTT pressed, speak into the microphone. An average deviation of 3 kHz (N) or 10 kHz (NW) indicates that 14RV1 is set correctly.
4. Whistle into microphone (app. 1 kHz). Deviation of 5 kHz (+0 –0.5 kHz) for N or 15 kHz (+0 –1 kHz) for NW, indicates that 14RV2 is set correctly.

Aerial Mismatch Protection (U14)

1. Remove all test equipment shown in Figure 1 except the Power Supply and Power Meter.
2. Set 14RV1 between the fully anti-clockwise and the centre positions.
3. Connect the AVO 8 (2.5V d.c.) between earth and the monitor point on U14.
4. Operate the PTT, tune 14C5 for minimum reading.
5. Connect the mismatch piece (39 pF 10W; 27 pF 25W) to the free end of the T-piece; this sets up a SWR of approximately 2:1 along the line.
6. Connect the AVO 8 (10V d.c.) between the emitter and collector of 13TS1 on U13.
7. Operate the PTT, adjust 14RV1 to obtain a reading of 4V on the AVO 8.
8. Remove the mismatch piece and check that the output power is restored without the PTT having to be re-operated.

Receiver Alignment and Test Procedure

Test Equipment

Equipment having similar characteristics to the items listed below may be used.

- (a) Hum-free Power Supply to give 13.8V d.c. minimum, 5A rating.
- (b) Multimeter – AVO 8
- (c) VTVM – Philips GM 6009
- (d) Signal Generator – Marconi TF 995/A5
- (e) 455 kHz Generator – Philips PM 5300
- (f) Audio Oscillator – Wayne Kerr
- (g) 10.7 MHz Marker
- (h) Distortion and Noise Meter – AWA
- (j) 6 dB terminating pad – Marconi
- (k) 20 dB attenuator pad – Marconi
- (l) Elec. Capacitor 25 μ F, 25 VW (2 off)
- (m) Resistor – 5 ohm 2 watt

NOTE: All component references are prefixed by the number of the board on which the components are mounted e.g. 2C4 refers to capacitor C4 on board U2.

Preparation

1. Connect the 13.8V Power Supply to the unit. Set the VOLUME control fully clockwise and the MUTE control fully anti-clockwise. Noise should be audible from the loudspeaker. Ensure that the output of the voltage regulator (U9 pin 3) is within 11.3V to 11.9V.

NOTE: Unless otherwise stated all S/N measurements are to be taken at an audio output of 200 mWatts

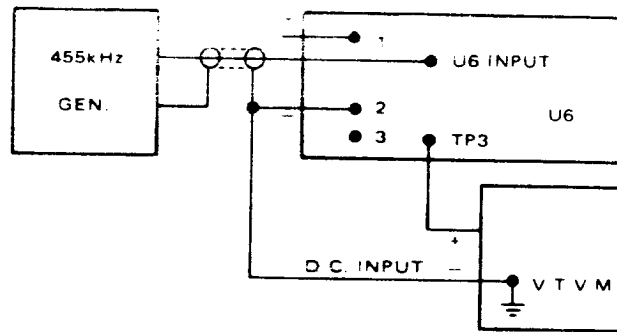

Figure 2

I.F. Alignment (U6)

1. Set up the equipment as shown in Figure 2.
2. Zero beat the 455 kHz signal generator with the 10.7 MHz marker and adjust the output to 300 μ V.
3. With the a.c. probe of the VTVM monitor the voltage at the following points:
 - (a) Junction 6C24/6C26 – tune 6L4 for maximum (app. 5V).
 - (b) 6TP2 – tune 6L3 for maximum (app. 100 mV).
 - (c) 6TP1 – tune 6L2 for maximum (app. 300 mV).
4. Connect the d.c. probe of the VTVM to 6TP3 and tune 6L5 for 0V.
5. To check the discriminator, vary the input frequency by 5 kHz (N) or 15 kHz (NW) and check that the change of output is ≥ 1 V (N) or ≥ 2 V (NW).

Oscillator Alignment (U5)

1. **Single Channel.** Set 5C7 and 5C8 to maximum capacitance and check that the correct crystal is in the receiver crystal socket.
2. Connect the AVO 8 (10V d.c.) between 5TP1 and the 11.4V +ve rail.
3. Adjust the netting coil slug for maximum voltage reading.
4. Tune 5C7 for minimum voltage reading.
5. Connect AVO 8 (2.5V d.c.) –ve lead to 4TP1 and the +ve lead to 4R5 (top loop).
6. Measure the voltage at 4TP1. Tune 5C8 and re-tune 5C7 alternately for maximum voltage reading.
7. **Multi-channel.** Select highest and lowest frequency crystal in turn. In each case, adjust 5C8 to give equal readings at 4TP1. Adjust coupling 5L2, 5L3 to give a reading of 0.7V–0.9V. This may require re-tuning of 5C8 and 5C7.

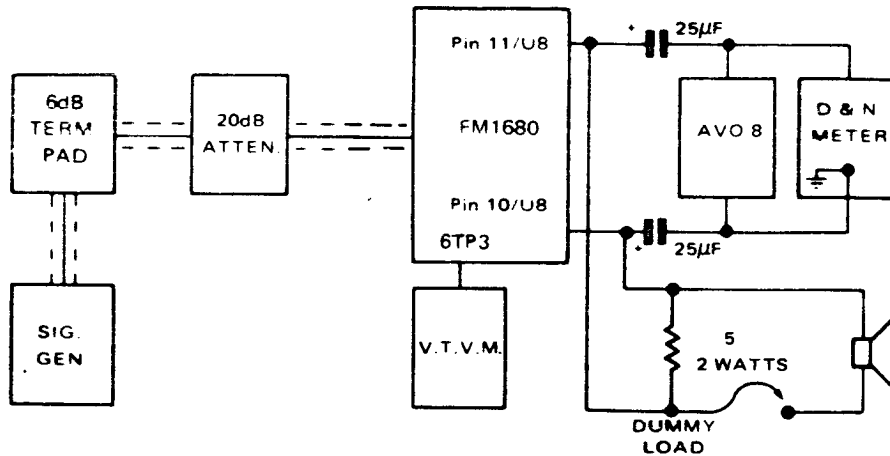

Figure 3

R.F. Alignment (U4)

1. Set up the equipment as shown in Figure 3.
2. Set 4C1, 4C3, 4C6 and 4C10 three turns out from the maximum capacitance position. Set the slug of 4L9 level with the top of the former.
3. Set the signal generator to the receiver channel frequency and adjust the output to give a S/N ratio of approximately 15 dB.
4. Adjust trimmers 4C1, 4C3, 4C6, 4C10 and 4L9 for maximum S/N ratio while gradually reducing the output of the signal generator until a S/N ratio of 32 dB (N) or 40 dB (NW) is obtained with an input of 1 μ V.
5. Increase the output of the signal generator by 10 dB and de-tune 4C3 until the original S/N ratio is obtained.
6. Tune 4C1 for maximum S/N ratio.
7. Tune 4C3 for maximum S/N ratio while decreasing the output of the signal generator to maintain a S/N ratio of 32 dB (N) or 40 dB (NW).
8. Increase the output of the signal generator by 20 dB and de-tune 4C10 until the original S/N ratio is obtained.
9. Tune 4C7 for maximum S/N ratio.
10. Re-tune 4C6, 4C10 while decreasing the output of the signal generator until a S/N ratio of 32 dB (N) or 40 dB (NW) is obtained.

Sensitivity

Note: All voltage sensitivity figures are p.d.

1. **Signal/Noise Ratio.** Set the signal generator deviation to 5 kHz (N) or 15 kHz (NW) at 1 kHz with 1 μ V input to the receiver. Adjust the receiver output to give 200 mWatts (1V across dummy load).
2. Remove audio modulation and check that the S/N ratio is not less than 32 dB (N) or 40 dB (NW).
3. **Image Response.** Set the signal generator to 21.4 MHz above the signal frequency, with 1 kHz modulation at 1.5 kHz (N) or 4.5 kHz (NW) deviation, and an input to the receiver of 8 mV.
4. Adjust the output of the receiver to 200 mWatts. Remove the audio modulation and check that the S/N ratio is not less than 10 dB.

Audio Output and Distortion

1. Set the signal generator to 1 kHz modulation with 3.3 kHz (N) or 10 kHz (NW) deviation.
2. Adjust the receiver input to $5\ \mu\text{V}$ and adjust the VOLUME control to give an output of 2 watts (3.16V across the dummy load).
3. Distortion must be $\leq 10\%$.

Phase Correction

1. Modulate the signal generator with the audio oscillator set to 1 kHz. Set the signal generator modulation deviation to 3 kHz with a receiver input of $5\ \mu\text{V}$.
2. Adjust the audio output to 0.9V across the dummy load.
3. Set the audio oscillator frequency to 300 Hz. The receiver output should rise by between 7.3 dB and 11.7 dB.
4. Increase the audio oscillator frequency to 1 kHz and check that the receiver output is still 0.9V.
5. Set the oscillator frequency to 3 kHz. Check that the output across the dummy load is between $-8.7\ \text{dB}$ and $-15\ \text{dB}$.

Squelch

1. Remove the dummy load and re-connect the loudspeaker.
2. Set the MUTE control so that the receiver is just squelched (loose squelch).
3. Set the signal generator for a modulation of 1 kHz at 5 kHz (N) or 15 kHz (NW) deviation.
4. Gradually increase the output of the signal generator until the signal is just audible as the carrier is turned on. Note the required signal level.
5. Set the MUTE control fully clockwise and increase the output of the signal generator until the receiver output becomes audible. Note the required level (tight squelch).
6. Limits:
 - Loose squelch $< 0.4\ \mu\text{V}$
 - Tight squelch $\geq 2 \times$ signal required for loose squelch but $< 4\ \mu\text{V}$.

Mod. Amp. Board U1

451-782-021

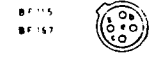
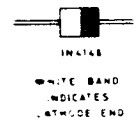
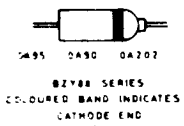
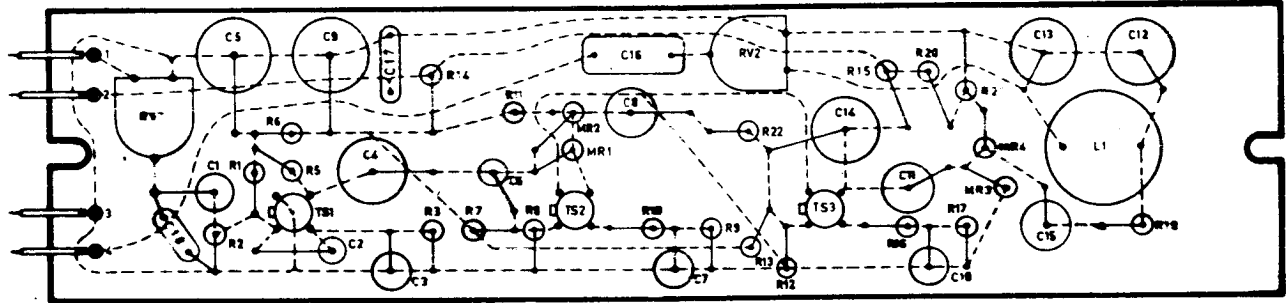
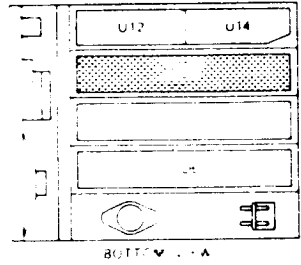

Parts List

CAPACITORS

Ref.	Value	Type	Tol.%	V.W.	Part No.
C1	4μF	E	+50 -10	40	055-237-540
C2	2200pF	C/T	+50 -20	500	056-154-222
C3	32μF	E	+50 -10	4	055-232-632
C4	4700pF	P/e	±10	400	053-253-247
C5	80μF	E	+50 -10	25	055-236-680
C6	0μ64	E	+100 -10	64	055-238-464
C7	32μF	E	+50 -10	4	055-232-632
C8	40μF	E	+50 -10	16	055-235-640
C9	80μF	E	+50 -10	25	055-236-680
C10	32μF	E	+50 -10	4	055-232-632
C11	25μF	E	+50 -10	25	055-236-625
C12	0μ01	P/e	±10	160	053-248-310
C13	0μ01	P/e	±10	160	053-248-310
C14	0μ012	P/e	±10	160	053-248-312
C15	25μF	E	+50 -10	25	055-236-625
C16	0μ1	P/e	±20	250	054-061-410
C17	0μ1	C/D	±20	25	054-173-410
C18	0μ01	C/D	+80 -20	25	056-173-310

RESISTORS

Ref.	Value	Type	Tol.%	W	Part No.
R1	39k	Carb.	±5	¼	062-023-339
R2	15k	Carb.	±5	¼	062-023-315
R3	1k	Carb.	±5	¼	062-023-210
R5	2k2	Carb.	±5	¼	062-023-222
R6	220	Carb.	±5	¼	062-023-122
R7	39k	Carb.	±5	¼	062-023-339
R8	15k	Carb.	±5	¼	062-023-315
R9	1k	Carb.	±5	¼	062-023-210
R10	22	Carb.	±5	¼	062-023-022
R11	2k2	Carb.	±5	¼	062-023-222
R12	6k8	Carb.	±5	¼	062-023-268
R13	22k	Carb.	±5	¼	062-023-322
R14	220	Carb.	±5	¼	062-023-122
R15	2k2	Carb.	±5	¼	062-023-222
R16	10	Carb.	±5	¼	062-023-010
R17	470	Carb.	±5	¼	062-023-147
R18	3k3	Carb.	±5	¼	062-023-233
R20	4k7	Carb.	±5	¼	062-023-247
R21	470	Carb.	±5	¼	062-023-147
R22	3k9	Carb.	±5	¼	062-023-239

SEMICONDUCTORS

Ref.	Description	Part No.
MR1	Diode Sil, OA202	079-111-001
MR2	Diode Sil, OA202	079-111-001
MR3	Diode Sil, 1N4148	079-124-001
MR4	Diode Sil, 1N4148	079-124-001
TS1	Trans. Sil, BC107	078-101-007
TS2	Trans. Sil, BF115	078-104-006
TS3	Trans. Sil, BF115	078-104-006

RESISTORS VARIABLE

Ref.	Description	Part No.
RV1	2k2 Min Trimmer ±20% 0.1 Watt	068-072-008
RV2	10k Min Trimmer ±20% 0.1 Watt	068-072-007

CHOKES, COILS AND INDUCTORS

Ref.	Description	Part No.
L1	Audio Filter Coil	451-782-039

Exciter Board U2

451-782-093

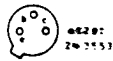
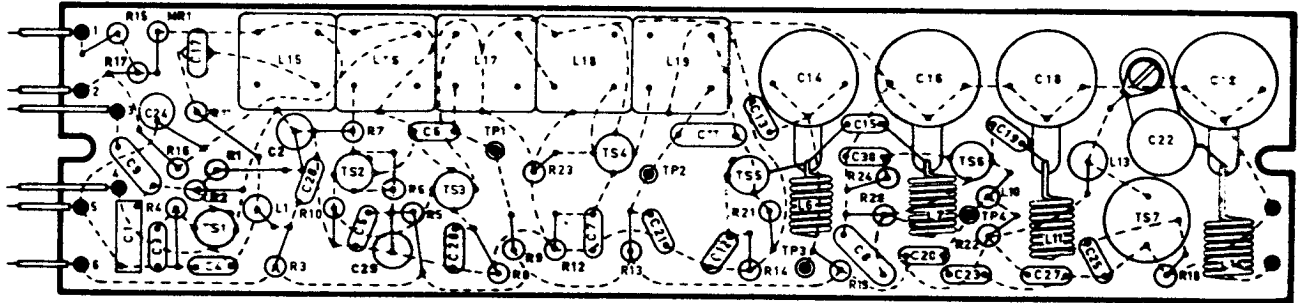
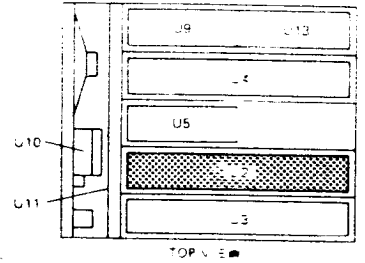

COLLECTOR
INTERMALLY
CONNECTED
TO THE BASE

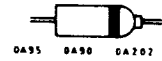

BZY88 SERIES
COLOURED BAND INDICATES
CATHODE END

Parts List

CAPACITORS

Ref.	Value	Type	Tol.%	V.W.	Part No.
C1	220pF	P/s	±10	100	053-017-122
C2	6µA	E	+50 -10	25	055-236-564
C3	0µ022	C/D	+80 -20	25	056-173-322
C4	39pF	C/D	+2%	500	051-134-039
C5	0µ022	C/D	+80 -20	25	056-173-322
C6	0µ022	C/D	+80 -20	25	056-173-322
C7	0µ01	C/D	+80 -20	25	056-173-310
C8	100pF	C/D	+10	500	053-154-110
C9	0µ022	C/D	+80 -20	25	056-173-322
C10	25pF	Air Trimmer		200	058-051-601
C11	100pF	C/D	+10	500	053-154-110
C12	560pF	C/D	+10	500	053-164-156
C13	0µ01	C/D	+80 -20	25	056-173-310
C14	25pF	Air Trimmer		200	058-051-601
C15	3p3	C/D	±0p25	500	051-124-933
C16	25pF	Air Trimmer		200	058-051-601
C17	2p2	C/D	±0p25	500	051-124-922
C18	25pF	Air Trimmer		200	058-051-601
C19	4p7	C/D	±0p25	500	051-124-947
C20	0µ022	C/D	+80 -20	25	056-173-322
C21	0µ022	C/D	+80 -20	25	056-173-322
C22	6pF	Cer. Trimmer		25	058-020-601
C23	0µ01	C/D	+80 -20	25	056-173-310
C24	560pF	P/s	+10	100	053-017-156
C25	100pF	C/D	+10	500	053-154-110

C26	0µ01	C/D	+80 -20	25	056-173-310
C27	0µ01	C/D	+80 -20	25	056-173-310
C28	0µ01	C/D	+80 -20	25	056-173-310
C29	10µF	E	+50 -10	16	055-235-610
C30	0µ01	C/D	+80 -20	25	056-173-310

RESISTORS

Ref.	Value	Type	Tol.%	W	Part No.
R1	18k	Carb.	±5	¼	062-023-318
R2	15k	Carb.	±5	¼	062-023-315
R3	1k	Carb.	±5	¼	062-023-210
R4	2k2	Carb.	±5	¼	062-023-222
R5	100	Carb.	±5	¼	062-023-110
R6	47k	Carb.	±5	¼	062-023-347
R7	15k	Carb.	±5	¼	062-023-315
R8	330	Carb.	±5	¼	062-023-133
R9	33	Carb.	±5	¼	062-023-033
R10	1k	Carb.	±5	¼	062-023-210
R11	15k	Carb.	±5	¼	062-023-315
R12	220	Carb.	±5	¼	062-023-122
R13	22	Carb.	±5	¼	062-023-022
R14	68	Carb.	±5	¼	062-023-068
R15	4k7	Carb.	±5	¼	062-023-247
R16	47k	Carb.	±5	¼	062-023-347
R17	100k	Carb.	±5	¼	062-023-410
R18	100	Carb.	±5	¼	062-023-110
R19	15	Carb.	±5	¼	062-023-015
R20	470	Carb.	±5	¼	062-023-147
R21	330	Carb.	±5	¼	062-023-133
R22	608	Carb.	±5	¼	062-023-968
R23	2k2	Carb.	±5	¼	062-023-222
R24	10	Carb.	±5	¼	062-023-010

SEMICONDUCTORS

Ref.	Description	Part No.
MR1	Diode Zener BZY88 C5V6	079-401-007
TS1	Trans. Sil. BF115	078-104-006
TS2	Trans. Sil. BF115	078-104-006
TS3	Trans. Sil. BF115	078-104-006
TS4	Trans. Sil. BF115	078-104-006
TS5	Trans. Sil. 2N2369	078-101-011
TS6	Trans. Sil. 2N2369	078-101-011
TS7	Trans. Sil. 2N3553	078-509-001

CHOKES, COILS AND INDUCTORS

Ref.	Description	Part No.
L1	R.F. Choke 22µH ±10%	047-622-501
L6	Third Doubler Coil	450-782-130
L7	Third Doubler Coil	450-782-130
L10	R.F. Choke	451-782-100
L11	Driver Input Coil	450-782-131
L13	R.F. Choke 0µ22 ±10%	042-422-501
L14	Driver Output Coil	450-782-132
L15	Modulator Coil	451-782-101
L16	Modulator Coil	451-782-103
L17	First Doubler Coil	451-782-105
L18	First Doubler Coil	451-782-107
L19	Second Doubler Coil	451-782-109

PA Unit U3

451-782-094 A/10N & A/10NW

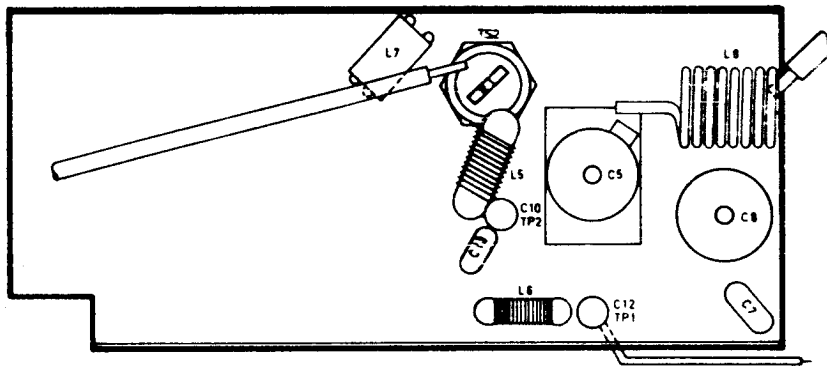
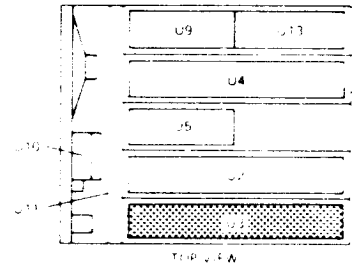

EMITTER INTERNALLY
CONNECTED TO THE
CASE

Parts List

CAPACITORS

Ref.	Value	Type	Tol.%	V.W.	Part No.
C5	25pF	Air Trimmer			058-051-602
C7	47pF	C/D	±2%	500	051-134-047
C8	25pF	Air Trimmer			058-051-602
C10	820pF	L/T	+100 -20	350	056-402-001
C12	820pF	L/T	+100 -20	350	056-402-001
C13	0.022	C/D	+80 -20	25	056-173-322

RESISTORS

Ref.	Value	Type	Tol.%	W	Part No.
R1	100	Carb.	±5	¼	062-023-110

SEMICONDUCTORS

Ref.	Description	Part No.
TS2	Trans. Sil. 2N3927	078-110-002

CHOKES, COILS AND INDUCTORS

Ref.	Description	Part No.
L5	PA Collector Coil	451-782-112
L6	Metering Coil	451-782-123
L7	R.F. Choke (Ferroxcube Bead)	450-734-093
L8	PA Tank Coil	450-782-135

PA Unit U3

451-782-130 A/25N & A/25NW

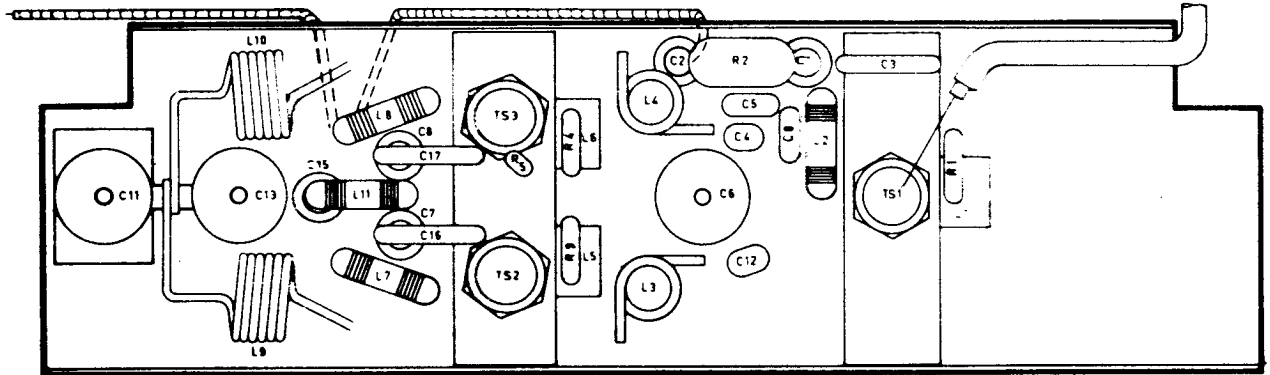
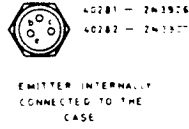
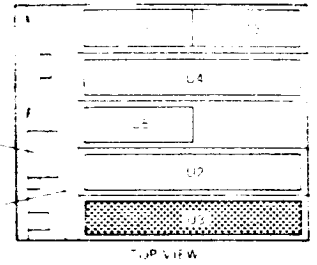

Parts List

CAPACITORS

Ref.	Value	Type	Tol. %	V.W.	Part No.
C1	820pF	L/T	+100 -20	350	056-402-001
C2	820pF	L/T	+100 -20	350	056-402-001
C3	0.1	C/D	+80 -20	25	056-173-410
C4	6p8	C/D	$\pm 0p25$	500	051-124-968
C5	22pF	C/D	$\pm 0p25$	500	051-124-022
C6	25pF	Air Trimmer			058-051-602
C7	820pF	L/T	+100 -20	350	056-402-001
C8	820pF	L/T	+100 -20	350	056-402-001
C9	10pF	C/D	$\pm 0p25$	500	051-124-010
C11	25pF	Air Trimmer			058-051-602
C12	6p8	C/D	$\pm 0p25$	500	051-124-968
C13	25pF	Air Trimmer			058-051-602
C15	820pF	L/T	+100 -20	350	056-402-001
C16	0.1	C/D	+80 -20	25	056-173-410
C17	0.1	C/D	+80 -20	25	056-173-410

RESISTORS

Ref.	Value	Type	Tol. %	W	Part No.
R1	33	Carb.	± 5	$\frac{1}{4}$	062-023-033
R2	0.47	W/W	± 20	2	064-051-847
R3	33	Carb.	± 5	$\frac{1}{4}$	062-024-033
R4	33	Carb.	± 5	$\frac{1}{4}$	062-024-033
R5	22	Carb.	± 5	$\frac{1}{4}$	062-023-022

SEMICONDUCTORS

Ref.	Description	Part No.
TS1	Trans. Sil. 2N3926	078-110-001
TS2	Trans. Sil. 2N3927	078-110-002
TS3	Trans. Sil. 2N3927	078-110-002

CHOKES, COILS AND INDUCTORS

Ref.	Description	Part No.
L1	R.F. Choke (Ferroxcube Bead)	450-734-093
L2	R.F. Choke	451-782-129
L3	PA Input Tuning Coil	450-782-165
L4	PA Input Tuning Coil	450-782-166
L5	R.F. Choke (Ferroxcube Bead)	450-734-093
L6	R.F. Choke (Ferroxcube Bead)	450-734-093
L7	R.F. Choke	451-782-129
L8	R.F. Choke	451-782-129
L9	PA Output Tuning Coil	450-782-167
L10	PA Output Tuning Coil	450-782-168
L11	Metering Coil	451-782-124

R.F. Board U4

451-782-095 A/10N & A/25N

451-782-135 A/10NW & A/25NW

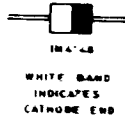
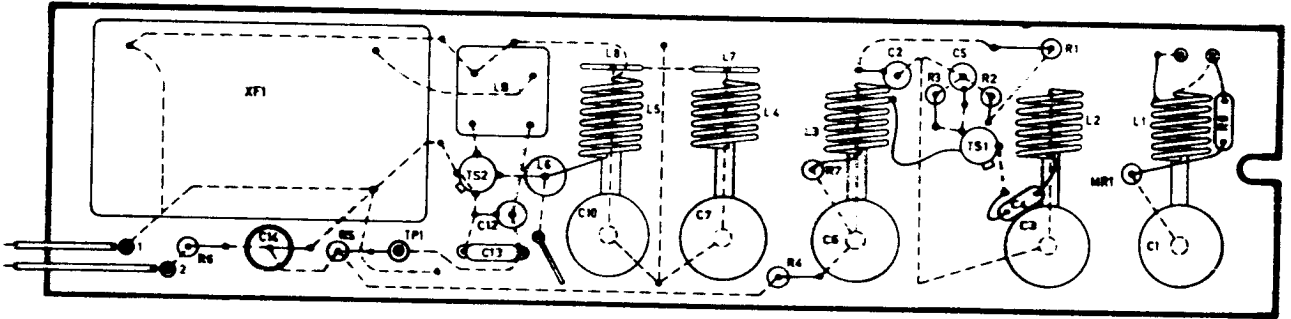
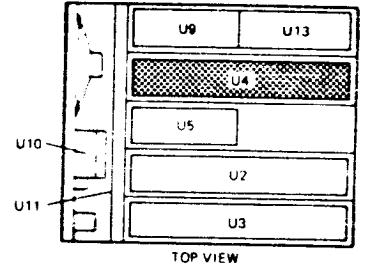

BF115
BF167



Parts List

451-782-095
A/10 N & A/25 N

CAPACITORS

Ref.	Value	Type	Tol.%	V.W.	Part No.
C1	25pF	Air Trimmer	200		058-051-601
C2	1000pF	C/T	+50	500	056-164-210
			-20		
C3	25pF	Air Trimmer	200		058-051-601
C4	3p3	C/D ±0p25	500		051-124-933
C5	1000pF	C/T	+50	500	056-164-210
			-20		
C6	25pF	Air Trimmer	200		058-051-601
C7	25pF	Air Trimmer	200		058-051-601
C10	25pF	Air Trimmer	200		058-051-601
C12	1000pF	C/T	+50	500	056-164-210
			-20		
C13	0.001	C/D	+80	25	056-173-310
			-20		
C14	40µF	E	+50	16	055-235-640
			-10		

RESISTORS

Ref.	Value	Type	Tol.%	W	Part No.
R1	3k9	Carb.	±5	¼	062-023-239
R2	1k	Carb.	±5	¼	062-023-210
R3	470	Carb.	±5	¼	062-023-147
R4	100	Carb.	±5	¼	062-023-110
R5	1k	Carb.	±5	¼	062-023-210
R6	100	Carb.	±5	¼	062-023-110
R7	10k	Carb.	±5	¼	062-023-310
R8	220	Carb.	±5	¼	062-023-122
R9	6k3	Carb.	±5	¼	062-023-268

SEMICONDUCTORS

Ref.	Description	Part No.
MR1	Diode Sil. 1N4148	079-124-001
TS1	Trans. Sil. BF167	078-104-005
TS2	Trans. Sil. BF115	078-104-006

CHOKES, COILS AND INDUCTORS

Ref.	Description	Part No.
L1	Aerial Coil	450-782-136
L2	R.F. Signal Coil	450-782-137
L3	R.F. Collector Coil	450-782-138
L4	R.F. Signal Coil	450-782-137
L5	R.F. Signal Coil	450-782-139
L6	Choke 2µ2 ±10%	042-522-501
L7	Coupling Coil	450-782-045
L8	Coupling Coil	450-782-045
L9	IF Input Assy.	451-782-060

CRYSTAL FILTER

Ref.	Description	Part No.
XL-F	Crystal Filter - Narrow Band	451-782-059

451-782-135
A/10 NW & A/25 NW

Components as for 451-782-095, with the following exceptions:

Ref.	Description	Part No.
L9	IF Input Assy	451-782 160
XL F	Crystal Filter Wide Band	451-782-141

Oscillator Board U5

451-782-096

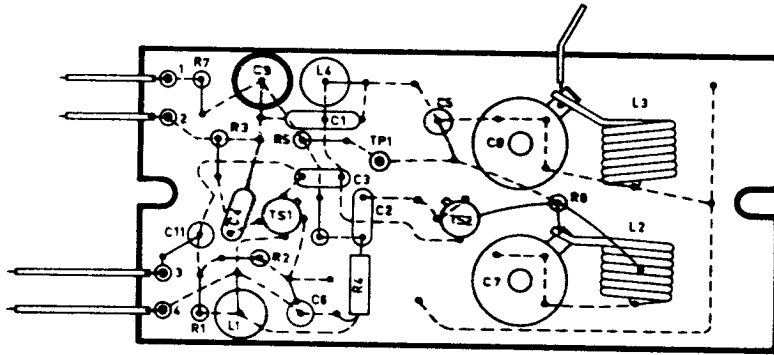
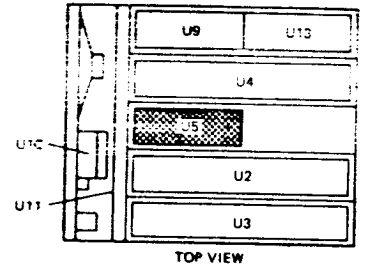

BF 115
BF 167



BC 107
BC 108
2N 2368



Parts List

CAPACITORS

Ref.	Value	Type	Tol.%	V.W.	Part No.
C1	68pF	C/T	±3	70	051-326-068
C2	0.001	C/D	+80 -20	25	056-173-310
C3	1000pF	C/D	±10	500	053-164-210
C4	0.01	P/e	±20	250	054-061-410
C5	1000pF	C/T	+80 -20	500	056-164-210
C6	12pF	C/P	±2	63	051-076-012
C7	10pF	Air Trimmer			058-051-001
C8	10pF	Air Trimmer			058-051-001
C9	40µF	E	+50 -10	16	055-235-640
C11	120pF	C/T	±3	70	051-326-112

RESISTORS

Ref.	Value	Type	Tol.%	W	Part No.
R1	27k	Carb.	±5	¼	062-023-327
R2	10k	Carb.	±5	¼	062-023-310
R3	680	Carb.	±5	¼	062-023-168
R4	4k7	Carb.	±5	¼	062-023-247
R5	1k	Carb.	±5	¼	062-023-210
R6	270	Carb.	±5	¼	062-023-127
R7	100	Carb.	±5	¼	062-023-110
R8	10k	Carb.	±5	¼	062-023-310

SEMICONDUCTORS

Ref.	Description	Part No.
TS1	Trans. SH. BC107	078-101-007
TS2	Trans. SH. BF 115	078-104-006

CHOKES, COILS AND INDUCTORS

Ref.	Description	Part No.
L1	R.F. Choke 4µH ±10%	042-547-501
L2	Tripler Coil	450-782-140
L3	Tripler Coil	450-782-141
L4	R.F. Choke 1µH ±10%	042-510-501

I.F. Board U6

451-782-026 A/10N & A/25N
451-782-133 A/10NW & A/25NW



BZY88 SERIES
COLOURED BAND INDICATES
CATHODE END

BF115
BF167

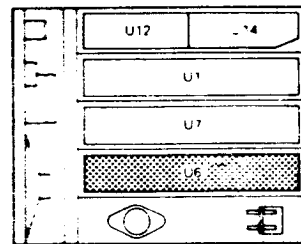

BOTTOM VIEW

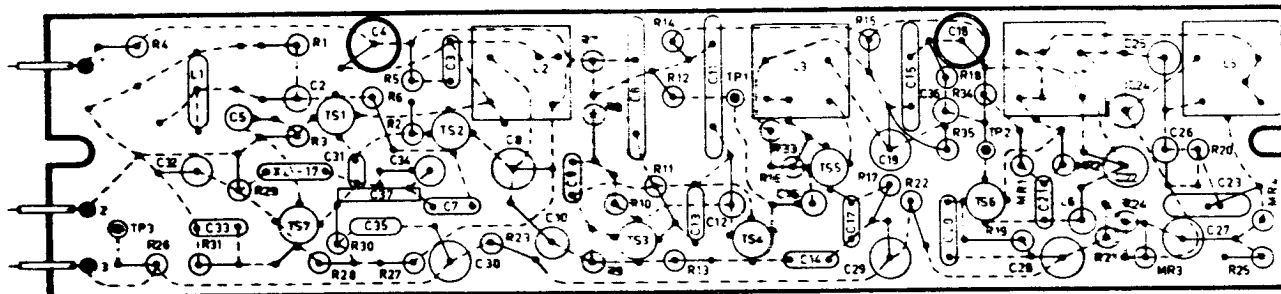

Parts List

451-782-026 A/10 N & A/25 N

CAPACITORS

Ref.	Value	Type	Tol.%	V.W.	Part No.
C2	1000pF	C/T	+50 -20	500	056-164-210
C3	0.01	C/D	+80 -20	25	056-173-310
C4	40µF	E	+50 -10	16	055-235-640
C5	1000pF	C/T	+50 -20	500	056-164-210
C6	0.022	C/D	+80 -20	25	056-173-422
C7	0.01	C/D	+80 -20	25	056-173-310
C8	2700pF	P/s	±2	125	051-017-227
C9	0.01	C/D	+80 -20	25	056-173-310
C10	270pF	P/s	±20	100	054-017-127
C11	0.022	C/D	+80 -20	25	056-173-422
C12	1000pF	C/T	+50 -20	500	056-164-210
C13	0.01	C/D	+80 -20	25	056-173-310
C14	0.047	C/D	+80 -20	25	056-173-347
C15	0.01	C/D	+80 -20	25	056-173-410
C16	1000pF	C/T	+50 -20	500	056-164-210
C17	0.01	C/D	+80 -20	25	056-173-310
C18	40µF	E	+50 -10	16	055-235-640
C19	2700pF	P/s	±2	125	051-017-227
C20	0.01	C/D	+80 -20	25	056-173-410
C21	0.01	C/D	+80 -20	25	056-173-310
C22	1800pF	P/s	±2	125	051-017-218
C23	150pF	S/M	±2%	500	051-424-115
C24	470pF	P/s	±5	100	052-017-147
C25	470pF	P/s	±5	100	052-017-147
C26	47pF	C/P	±2	63	051-186-047
C27	680pF	C/P	±20	100	054-017-168
C28	680pF	P/s	±20	100	054-017-168
C29	680pF	P/s	±20	100	054-017-168

C30	680pF	P/s	±20	100	054-017-168
C31	3p3	C/D	±0p25	500	051-124-933
C32	470pF	P/s	±20	100	054-017-147
C33	0.01	C/D	+80 -20	25	056-173-310
C34	18pF	C/P	±2	63	051-076-018
C35	0.01	C/D	+80 -20	25	056-173-310
C36	33pF	C/T	±2	63	051-186-033
C37	6p8	C/T	±0p5	500	051-194-968

RESISTORS

Ref.	Value	Type	Tol.%	W	Part No.
R1	3k3	Carb.	±5	¼	062-023-233
R2	470	Carb.	±5	¼	062-023-147
R3	3k3	Carb.	±5	¼	062-023-233
R4	100	Carb.	±5	¼	062-023-110
R5	3k9	Carb.	±5	¼	062-023-239
R6	3k3	Carb.	±5	¼	062-023-233
R7	100	Carb.	±5	¼	062-023-110
R8	3k3	Carb.	±5	¼	062-023-233
R9	1k5	Carb.	±5	¼	062-023-215
R10	1k	Carb.	±5	¼	062-023-210
R11	1k5	Carb.	±5	¼	062-023-215
R12	1k2	Carb.	±5	¼	062-023-212
R13	1k5	Carb.	±5	¼	062-023-215
R14	100	Carb.	±5	¼	062-023-110
R15	2k2	Carb.	±5	¼	062-023-222
R16	3k3	Carb.	±5	¼	062-023-233
R17	1k	Carb.	±5	¼	062-023-210
R18	4k7	Carb.	±5	¼	062-023-247
R19	680	Carb.	±5	¼	062-023-168
R21	680	Carb.	±5	¼	062-023-168
R22	680	Carb.	±5	¼	062-023-168
R23	680	Carb.	±5	¼	052-023-168
R24	33k	Carb.	±5	¼	062-023-333
R25	33k	Carb.	±5	¼	062-023-333
R26	82k	Carb.	±5	¼	062-023-382
R27	100	Carb.	±5	¼	062-023-110
R28	10k	Carb.	±5	¼	062-023-310
R29	2k7	Carb.	±5	¼	062-023-227
R30	1k8	Carb.	±5	¼	062-023-218
R31	1k5	Carb.	±5	¼	062-023-215
R33	6k8	Carb.	±5	¼	062-023-268
R34	4k7	Carb.	±5	¼	062-023-247
R35	6k8	Carb.	±5	¼	062-023-268

SEMICONDUCTORS

Ref.	Description	Part No.
MR1	Diode Ger. OA90	079-212-001
MR2	Diode Ger. OA90	079-212-001
MR3	Diode Ger. OA90	079-212-001
MR4	Diode Ger. OA90	079-212-001
TS1	Trans. Sil. BF115	078-104-006
TS2	Trans. Sil. BF115	078-104-006
TS3	Trans. Sil. BF115	078-104-006
TS4	Trans. Sil. BF115	078-104-006
TS5	Trans. Sil. BF115	078-104-006
TS6	Trans. Sil. BF115	078-104-006
TS7	Trans. Sil. BF115	078-104-006

CHOKES, COILS AND INDUCTORS

Ref.	Description	Part No.
L1	R.F. Choke 10µH ±10%	042-610-501
L2	IF Coil 455kHz	451-782-064
L3	IF Coil 455kHz	451-782-065
L4	IF Coil 455kHz	451-782-066
L5	Discriminator Coil 455kHz	451-782-067
L6	Choke 1mH	042-810-501

CRYSTAL

Ref.	Description	Part No.
XL-M	2nd Osc. Crystal	450-782-061

451-782-133 A/10 NW & A/25 NW

Components as for 451-782-026 with the following exceptions:

CAPACITORS

Ref.	Value	Type	Tol.%	V.W.	Part No.
C10	470pF	P/s	±20	100	054-017-147
C36	1000pF	C/D	±10	500	053-164-210

RESISTORS

Ref.	Value	Type	Tol.%	W	Part No.
R20	22k	Carb.	±5	¼	062-023-322
R35	NIL				

Audio Board U7

451-782-027 A/10N & A/25N

451-782-134 A/10NW & A/25NW

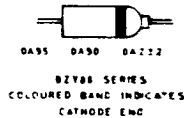
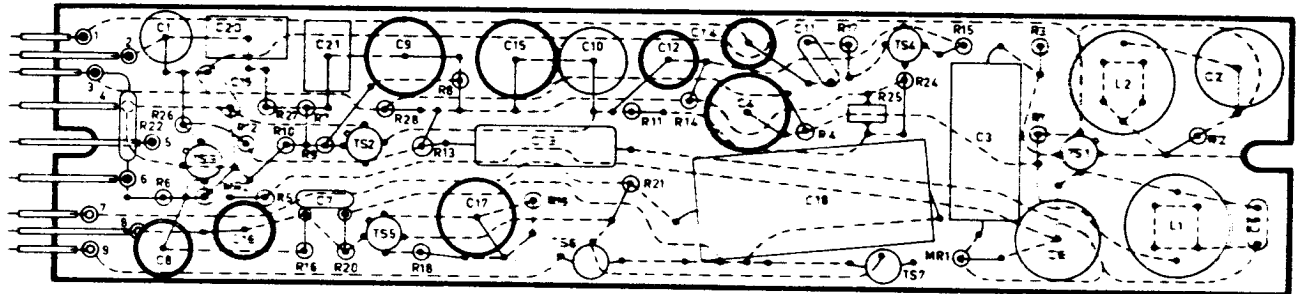
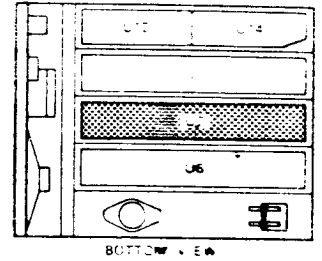

Parts List

451-782-027
A/10 N & A/25 N

RESISTORS

SEMICONDUCTORS

CAPACITORS					
Ref.	Value	Type	Tol.%	V.W.	Part No.
C1	2700pF	P/e	±2	125	051-017-227
C2	0.12	P/e	±10	160	053-248-412
C3	1μF	P/e	±10	100	053-057-515
C4	125μF	E	+50	16	055-000-003
			-10		
C5	330pF	C/D	±10	500	053-164-133
C6	0.15	P/e	±10	160	053-248-415
C7	0.01	C/D	+80	25	056-173-310
			-20		
C8	10μF	E	+50	16	055-235-610
			-10		
C9	125μF	E	+50	16	055-000-003
			-10		
C10	0.015	P/e	±10	160	053-248-315
C11	1000pF	C/D	±10	500	053-164-210
C12	40μF	E	+50	16	055-235-640
			-10		
C13	64μF	E	+50	10	055-234-664
			-10		
C14	40μF	E	+50	16	055-235-640
			-10		
C15	125μF	E	+50	16	055-000-003
			-10		
C16	40μF	E	+50	16	055-235-640
			-10		
C17	125μF	E	+50	16	055-000-003
			-10		
C18	330μF	E	±20	6.3	055-233-733
C19	560pF	C/D	±10	500	053-164-156
C20	0.22	P/e	±10	100	053-057-422
C21	0.22	P/e	±10	100	053-057-422

Ref.	Value	Type	Tol.%	W	Part No.
R1	33k	Carb.	±5	¼	062-023-333
R2	6k8	Carb.	±5	¼	062-023-268
R3	330	Carb.	±5	¼	062-023-133
R4	100	Carb.	±5	¼	062-023-110
R5	4k7	Carb.	±5	¼	062-023-247
R6	10k	Carb.	±5	¼	062-023-310
R7	3k9	Carb.	±5	¼	062-023-239
R8	220	Carb.	±5	¼	062-023-122
R9	47k	Carb.	±5	¼	062-023-347
R10	10k	Carb.	±5	¼	062-023-310
R11	1k5	Carb.	±5	¼	062-023-215
R12	330	Carb.	±5	¼	062-023-133
R13	56k	Carb.	±5	¼	062-023-356
R14	18k	Carb.	±5	¼	062-023-318
R15	22k	Carb.	±5	¼	062-023-322
R16	1k5	Carb.	±5	¼	062-023-215
R17	2k2	Carb.	±5	¼	062-023-222
R18	10	Carb.	±5	¼	062-023-010
R19	47	Carb.	±5	¼	062-023-047
R20	5k6	Carb.	±5	¼	062-023-256
R21	680	Carb.	±5	¼	062-023-168
R22	68k	Carb.	±5	¼	062-023-368
R24	2k7	Carb.	±5	¼	062-023-227
R25	470	Thermistor	±20		064-104-147
R26	47k	Carb.	±5	¼	062-023-347
R27	12k	Carb.	±5	¼	062-023-312
R28	100	Carb.	±5	¼	062-023-110

Ref.	Description	Part No.
MR1	Diode Sil. OA202	079-124-001
MR2	Diode Ger. OA90	079-212-001
TS1	Trans. Sil. BF115	078-104-006
TS2	Trans. Sil. BF115	078-104-006
TS3	Trans. Sil. BC109	078-101-009
TS4	Trans. Sil. BF115	078-104-006
TS5	Trans. Sil. BC107	078-101-007
TS6	Trans. Sil. Matched Pair	078-000-001
TS7	AC187/AC188	

451-782-134
A/10 NW & A/25 NW

Components as for 451-782-027 with the following exceptions:

CHOKES, COILS AND INDUCTORS

Ref.	Description	Part No.
L1	Peeking Inductor	451-782-073
L2	Peeking Inductor	451-782-073

CAPACITORS

Ref.	Value	Type	Tol.%	V.W.	Part No.
C5	3900pF	C/D	±10	500	053-164-239
C19	1000pF	C/D	±10	500	053-164-210

RESISTORS

Ref.	Value	Type	Tol.%	W	Part No.
R22	150k	Carb.	±5	¼	062-023-415

Front Panel Assembly U8

451-782-028

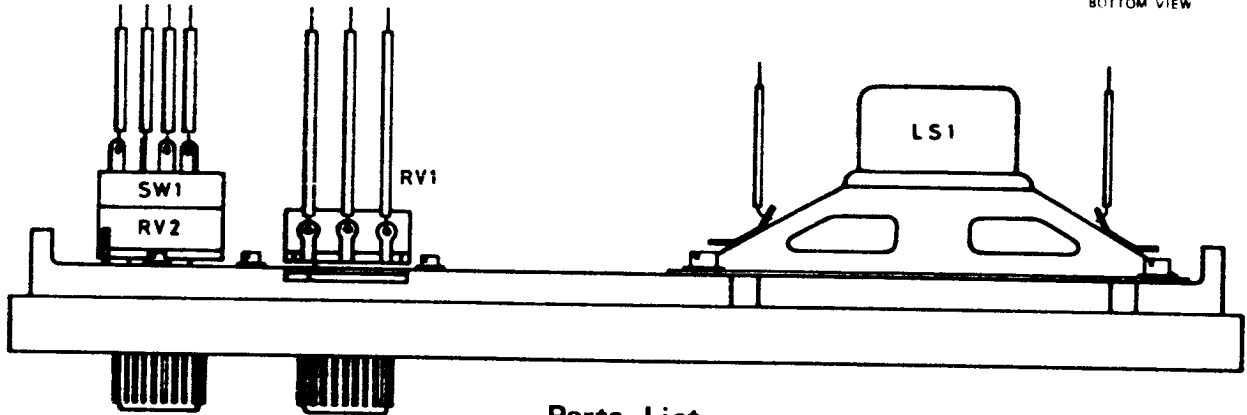
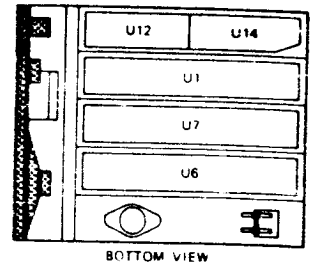

Parts List

RESISTORS VARIABLE

Ref.	Description	Part No.
RV1	Pot'meter 5k \pm 20% 1/2 Watt	068-042-002
RV2	Pot'meter and DPST switch	068-043-001
SW1	50k \pm 20% 1/2 Watt	

LOUDSPEAKER

Ref.	Description	Part No.
LS1	Loudspeaker 5 ohm (4 in. x 2 3/4 in.) (10.16 cms x 7 cms) Speaker Gauze	450-782-063 450-782-060

Voltage Regulator Board U9

451-782-029

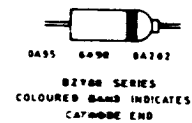
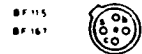
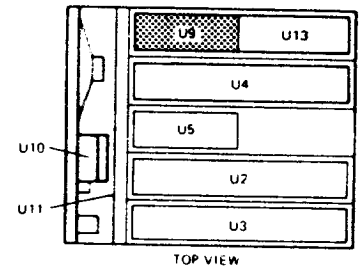
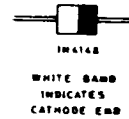
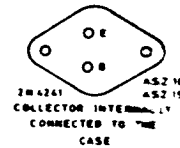
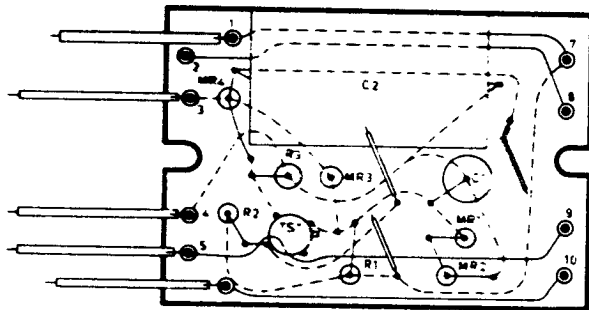

Parts List

CAPACITORS

Ref.	Value	Type	Tol.%	V.W.	Part No.
C1	25 μ F	E	+50 -10	25	055-236-625
C2	640 μ F	E	+50 -10	16	055-235-764

RESISTORS

Ref.	Value	Type	Tol.%	W	Part No.
R1	560	Carb.	\pm 5	1/4	062-023-156
R2	150	Carb.	\pm 5	1/4	062-023-115
R3	680	Carb.	\pm 5	1/4	062-024-168

SEMICONDUCTORS

Ref.	Description	Part No.
MR1	Diode Sil. BZY 88/C4V7	079-401-005
MR2	Diode Sil. BZY 88/C6V8	079-401-008
MR3	Diode Sil. 1N4148	079-124-001
MR4	Diode Sil. 1N4148	079-124-001
TS1	Trans. Sil. BF115	078-104-006
TS2	Trans. Ger. ASZ16	078-803-004

Crystal Kit U10S

451-782-097

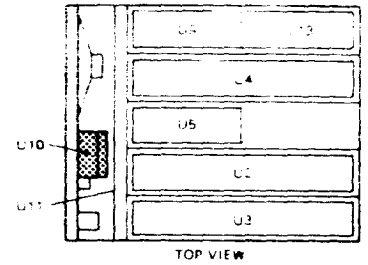
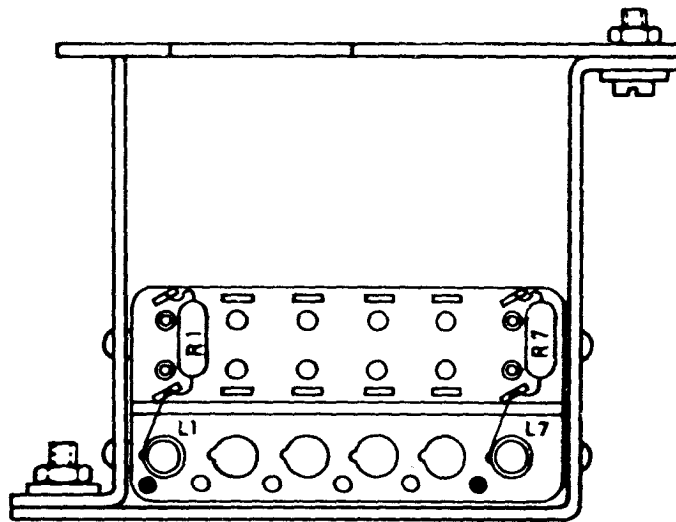

Parts List

RESISTORS

Ref.	Value	Type	Tol.%	W	Part No.
R1	1k	Carb.	±5	¼	062-023-210
R7	1k5	Carb.	±5	¼	062-023-215

CHOKES, COILS AND INDUCTORS

Ref.	Description	Part No.
L1	Netting Coil	451-782-113
L7	Netting Coil	451-782-114

Crystal Kit U10M

451-782-140

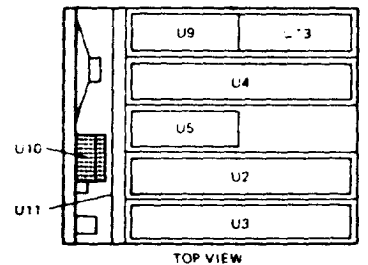
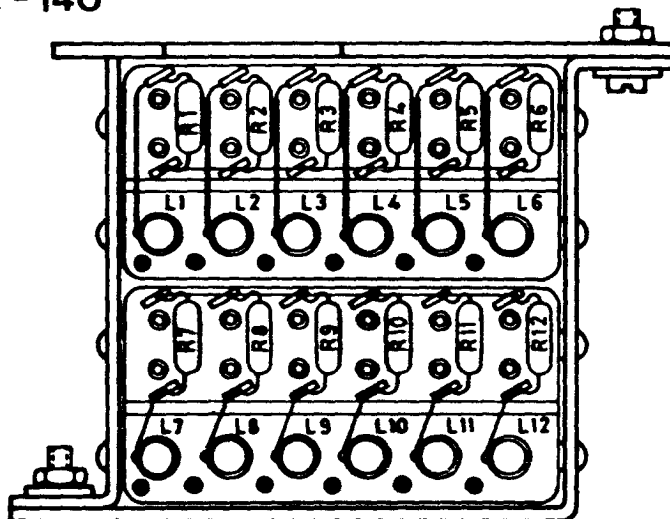

Switch removed to show wiring & components

Parts List

RESISTORS

Ref.	Value	Type	Tol.%	W	Part No.
R1	1k	Carb.	±5	¼	062-023-210
R2	1k	Carb.	±5	¼	062-023-210
R3	1k	Carb.	±5	¼	062-023-210
R4	1k	Carb.	±5	¼	062-023-210
R5	1k	Carb.	±5	¼	062-023-210
R6	1k	Carb.	±5	¼	062-023-210
R7	1k5	Carb.	±5	¼	062-023-215
R8	1k5	Carb.	±5	¼	062-023-215
R9	1k5	Carb.	±5	¼	062-023-215
R10	1k5	Carb.	±5	¼	062-023-215
R11	1k5	Carb.	±5	¼	062-023-215
R12	1k5	Carb.	±5	¼	062-023-215

CHOKES, COILS AND INDUCTORS

Ref.	Description	Part No.
L1	Netting Coil	451-782-139
L2	Netting Coil	451-782-139
L3	Netting Coil	451-782-139
L4	Netting Coil	451-782-139
L5	Netting Coil	451-782-139
L6	Netting Coil	451-782-139
L7	Netting Coil	451-782-114
L8	Netting Coil	451-782-114
L9	Netting Coil	451-782-114
L10	Netting Coil	451-782-114
L11	Netting Coil	451-782-114
L12	Netting Coil	451-782-114

SWITCH

Ref.	Description	Part No.
SW1	Switch NSF Oak Model A 450-782-204	

Filter and Relay Unit U12

451-782-098

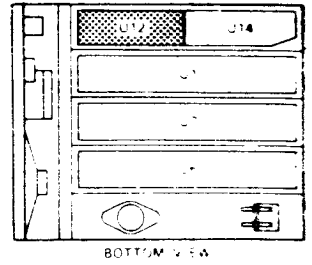
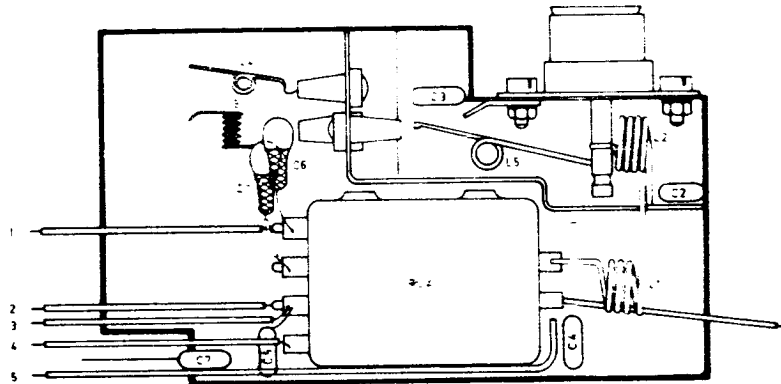

Parts List

CAPACITORS

Ref.	Value	Type	Tol.%	V.W.	Part No.
C1	18pF	C/T	±1pF	70	051-076-018
C2	56pF	C/D	±2%	500	051-134-056
C3	27pF	C/D	±2%	500	051-134-027
C4	1000pF	C/D	±10	500	053-164-210
C5	1000pF	C/D	±10	500	053-164-210
C6	18pF	C/D	±1pF	70	051-076-018
C7	0.022	C/D	+80	25	056-173-322
			-20		

CHOKES, COILS AND INDUCTORS

Ref.	Description	Part No.
L1	Harmonic Filter Coil	450-782-142
L2	Harmonic Filter Coil	450-782-143
L3	Harmonic Filter Coil	450-782-144
L4	Harmonic Filter Coil	450-782-144
L5	Harmonic Filter Coil	450-782-145

RELAYS

Ref.	Description	Part No.
RLA	Haller Relay NE50962	450-782-074

Polarity Rev SIC Protection Card U13

451-782-033 A/10

451-782-118 A/25

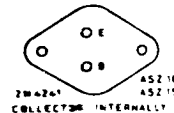
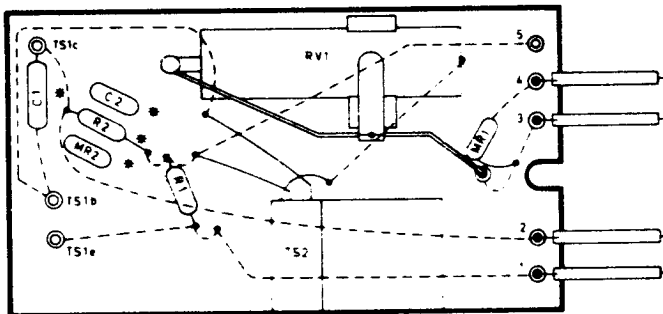

WHITE BAND INDICATES CATHODE END

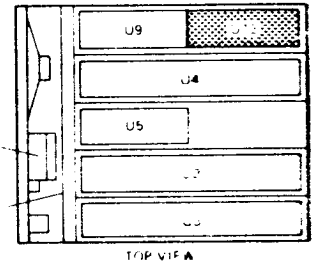

BZY88 SERIES COLOURED BAND INDICATES CATHODE END

Parts List

CAPACITORS

Ref.	Value	Type	Tol.%	V.W.	Part No.
* C1	4μF	E	+50	40	055-237-540
			-10		
* C2	0.001	C/D	20	25	218-070-310

RESISTORS

Ref.	Value	Type	Tol.%	V.W.	Part No.
R1	2k2	Carb.	±5	¼	062-023-222
* R2	2k2	Carb.	±5	¼	062-023-222

RESISTOR VARIABLE

Ref.	Description	Part No.
RV1	Resistor Variable 250 ohm ±10% 0.6 Watt	068-112-007

SEMICONDUCTORS

Ref.	Description	Part No.
MR1	Diode Sil. OA202	079-111-001
* MR2	Diode Sil. 1N4148 (25W only)	079-124-001
TS1	Trans. Ger. ASZ15 (10W only)	078-803-003
TS1	Trans. Ger. 2N4241 (25W only)	078-803-005
TS2	Trans. Ger. AC127 Transistor Assy.	078-306-001 451-782-035

* NOTE C1 and R2 are included in 10 Watt models only. In 25 Watt models R2 is replaced by MR2 and C2 in parallel. TS1's are mounted on a separate heat-sink.

Aerial Mismatch Protection Unit U14

451-782-034 A/10

451-782-127 A/25

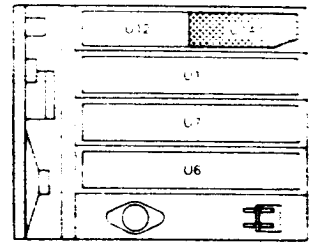

BOTTOM VIEW

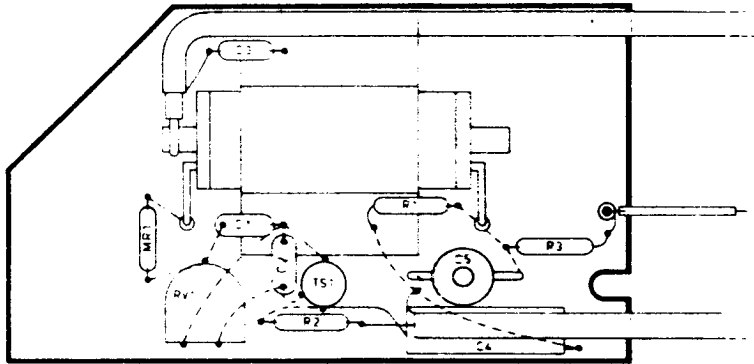

BC 107
BC 109
2H 2269

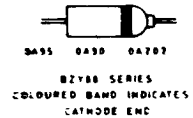

Parts List

451-782-034 A/10

CAPACITORS					
Ref.	Value	Type	Tol. %	V.W.	Part No.
C1	0.001	C/D	+80 -20	25	056-173-310
C2	0.001	C/D	+80 -20	25	056-173-310
C3	0.001	C/D	+80 -20	25	056-173-310
C4	10µF	E	+50 -10	16	055-235-610
C5	22pF	Trimmer			058-011-501

RESISTORS

Ref.	Value	Type	Tol. %	W	Part No.
R1	82	Carb.	±5	¼	062-023-082
R2	100	Carb.	±5	¼	062-023-110
R3	1k5	Carb.	±5	¼	062-023-215

RESISTOR VARIABLE

Ref.	Description	Part No.
RV1	Min. Trimmer 10k ±20% 0.1W	068-072-007

SEMICONDUCTORS

Ref.	Description	Part No.
MR1	Diode Ger. OA95	079-212-002
TS1	Trans. Sil. BC107	078-101-007

451-782-127 A/25

Components as for 451-782-034,
with the following exception:

CAPACITOR

Ref.	Value	Type	Tol. %	V.W.	Part No.
C4	40µF	E	+50 -10	16	055-235-640

Miscellaneous

Parts List

Ref.	Description	Part No.		
U11	Interwiring Board	451-782-012	Microphone Assy.	451-000-003
FS1	2A (10 Watt model)	034-113-002	Battery Connector Assy.	451-782-036
FS1	5A (25 Watt model)	034-113-005	Mounting Tray	451-757-090
FS2	2A (10 Watt model)	034-113-002	Microphone Bracket	451-757-089
FS2	5A (25 Watt model)	034-113-005	Whip Aerial Assy.	451-757-016
C3	Cap C/D 0.01 ± 20% 25VW	054-173-410	Volume Control Knob Assy.	451-782-186
XL R1			Mute Control Knob Assy.	451-782-186
to	Receiver Crystals	3502 150-0558.2	Channel Selector Knob Assy.	451-782-187
XL R6				
XL T1				
to	Transmitter Crystals	3502 150-0560.2		
XL T6				

C BAND (148-174MHz)

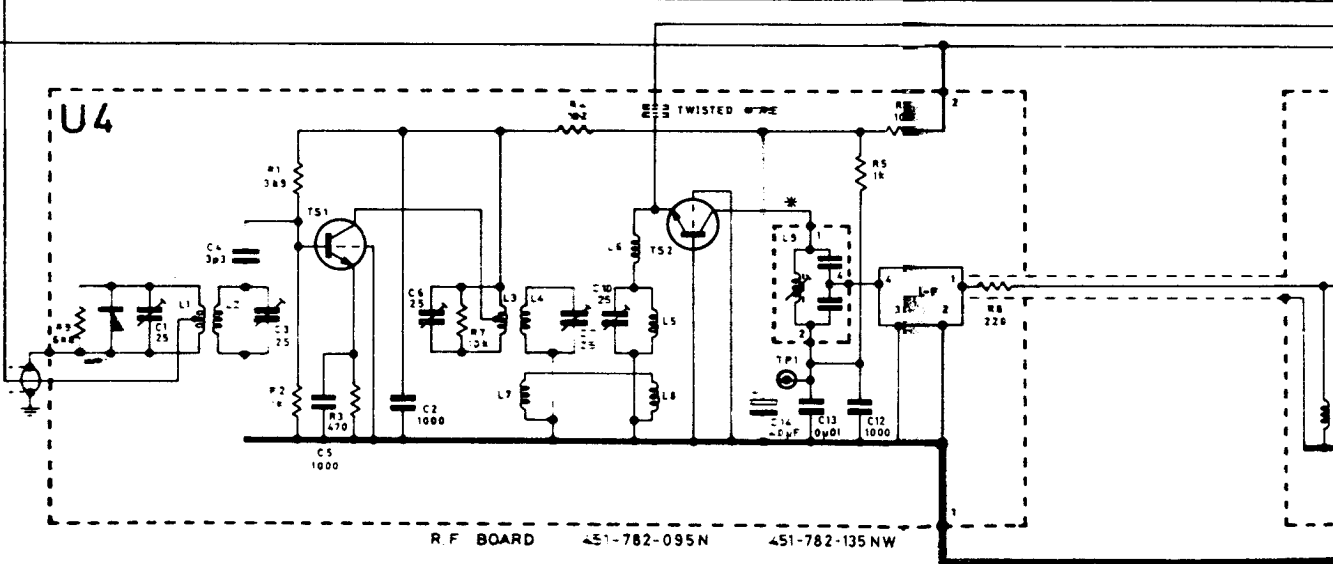
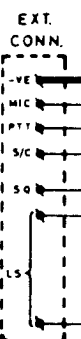
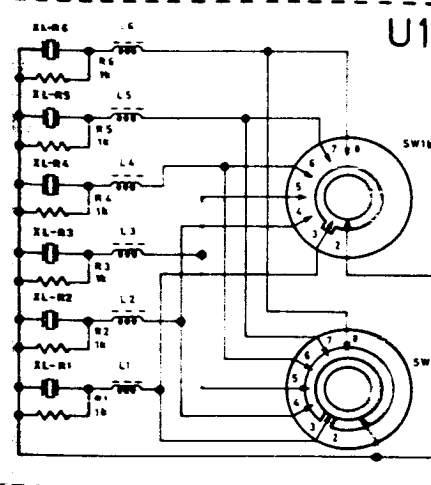
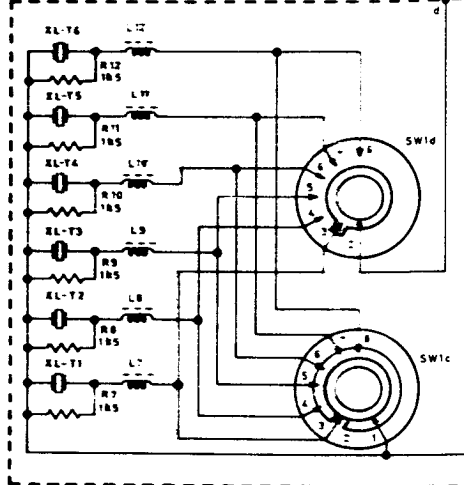
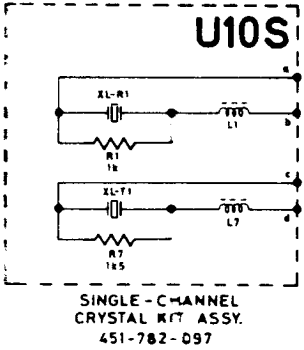
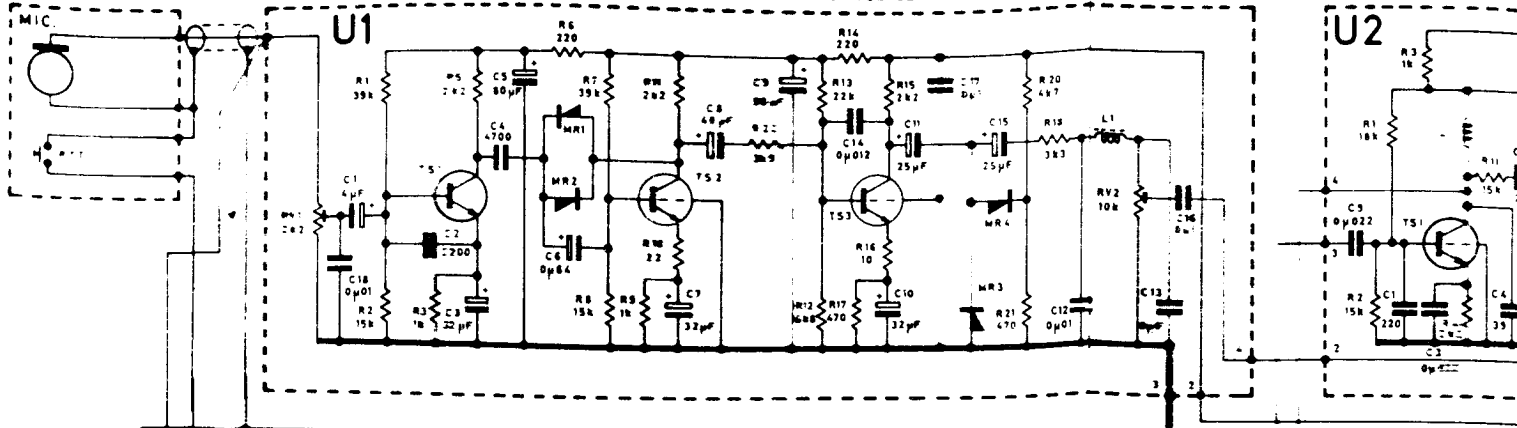

NOTE:
 PA Unit U3
 451-782-094 is installed in
 model A10
 451-782-130 is installed in
 model A25

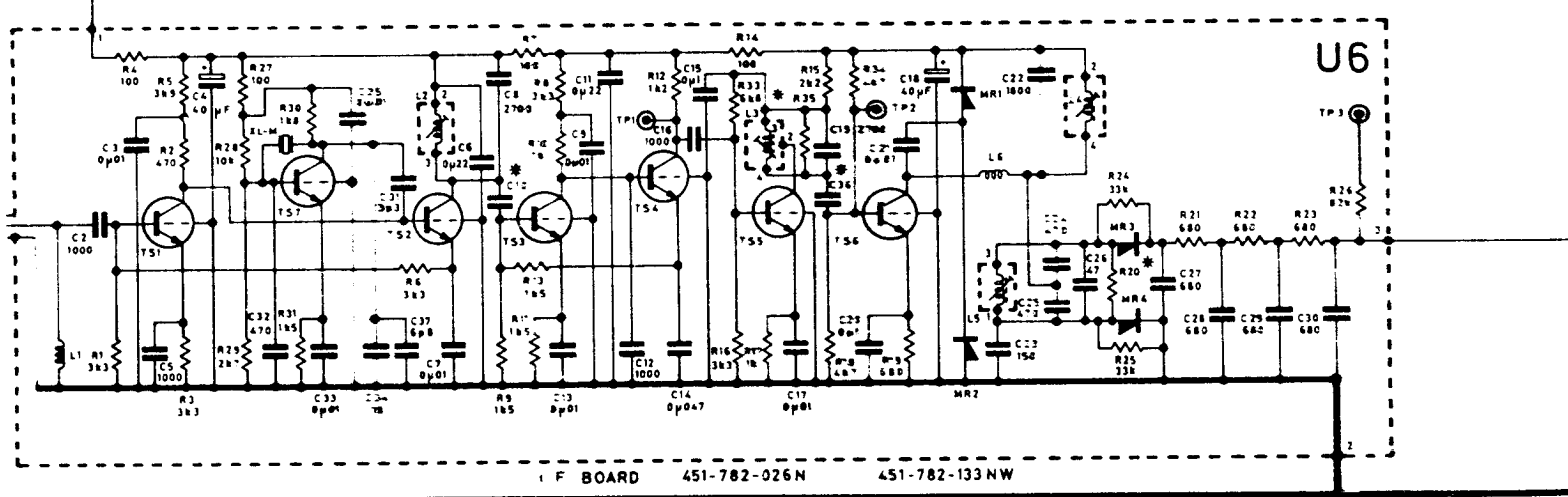
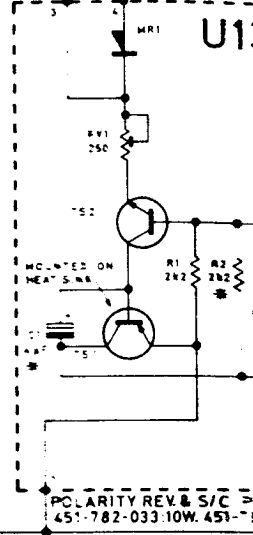
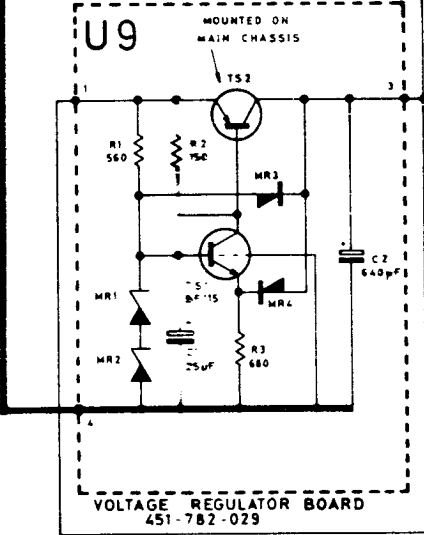
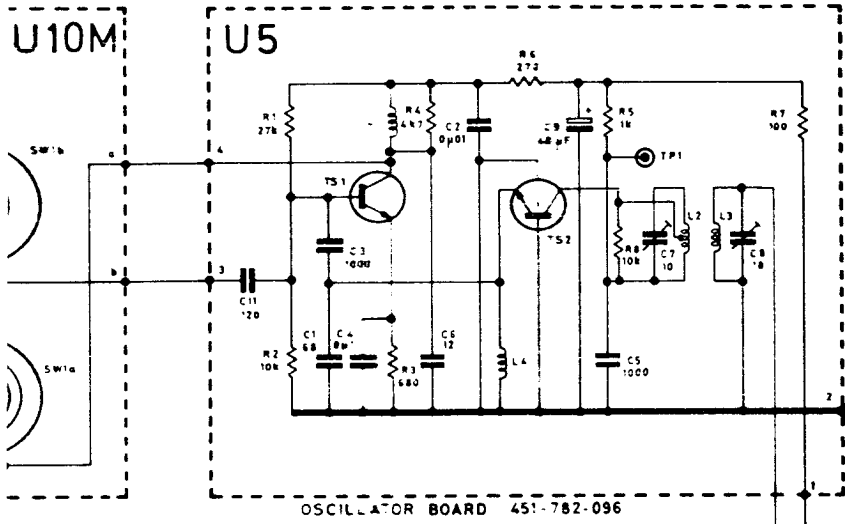
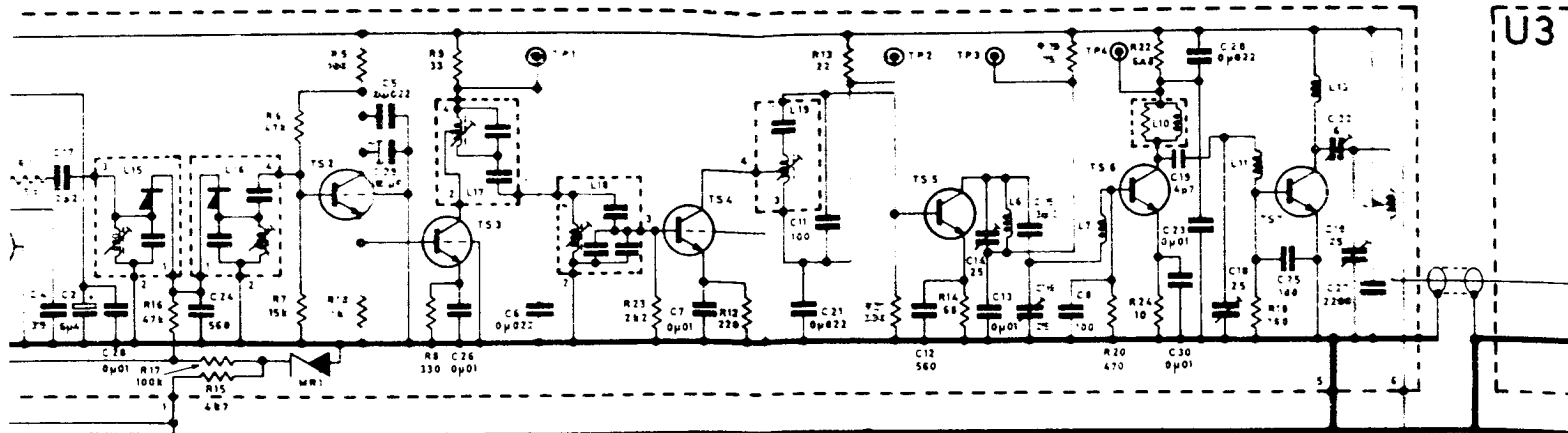

* ALTERNATIVE COMPONENTS FOR U4, U6, U7, U13 & U14

COMPONENT	U4 XL-F	U4 L9	U6 R20	U6 R35	U6 C36	U6 C10	U7 C5	U7 C19	U7 R22	U13 R2	U13 MR2	U13 C1
NARROW BAND (N)	451-782-059	451-782-060	None	6k8	33pF	270pF	330pF	560pF	68k	Only on	Only on	Only on
WIDE BAND (NW)	451-782-141	451-782-160	22k	None	1000pF	470pF	390pF	1000pF	150k	10 Watt	25 Watt	10 Watt

VOLTAGE ANALYSIS (V d.c. wrt -ve earth)	U1/TS1	U1/TS2	U1/TS3	U4/TS1	U4/TS2	U5/TS1	U5/TS2	U6/TS1	U6/TS2	U6/TS3	U6/TS4	U6/TS5	U6/TS6	U6/TS7	U7/TS1	U7/TS2
e	1.8	1.3	1.6	1.3	0	2.0	0	2.5	6.4	1.4	4.3	0.8	3.4	1.4	0.5	0.5
b	2.4	2.5	2.2	2.0	0	2.7	0	3.2	6.9	2.1	4.9	1.5	4.1	2.1	1.2	1.2
c	6.0	6.3	4.6	10.4	10.9	10.7	11.2	6.9	10.2	4.9	7.6	4.8	8.6	8.1	11.0	11.0

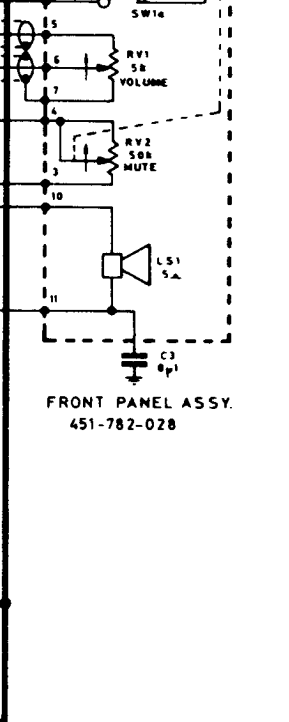
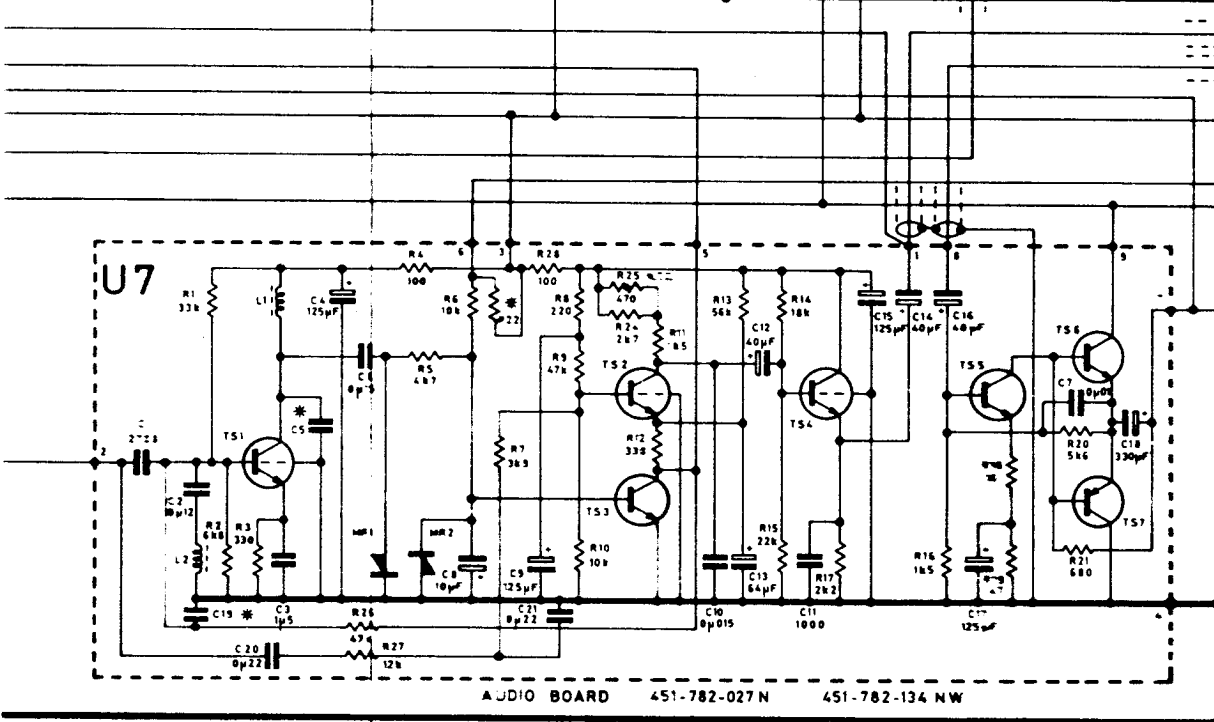
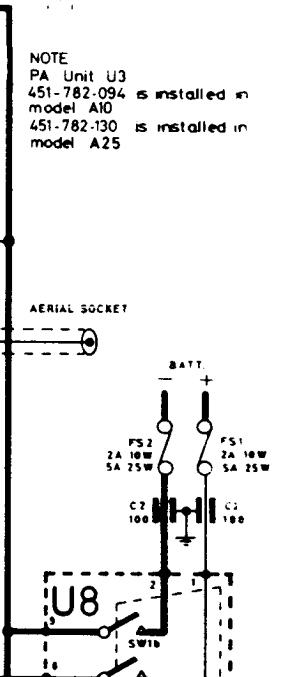
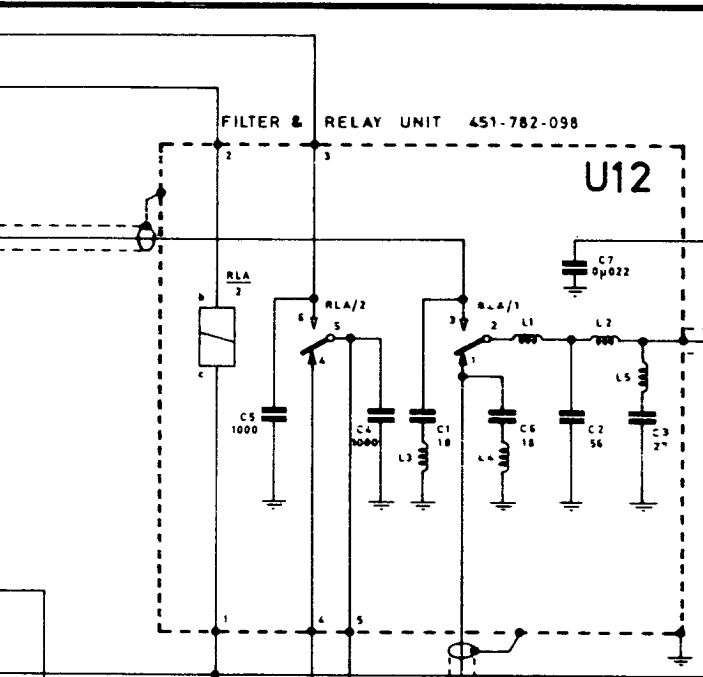
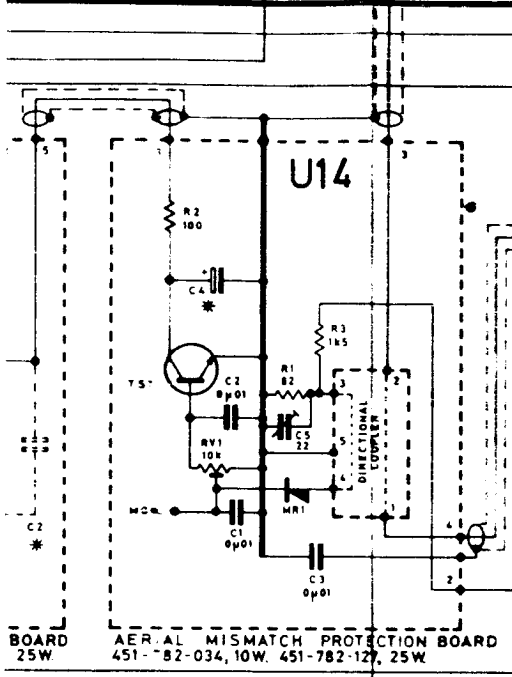
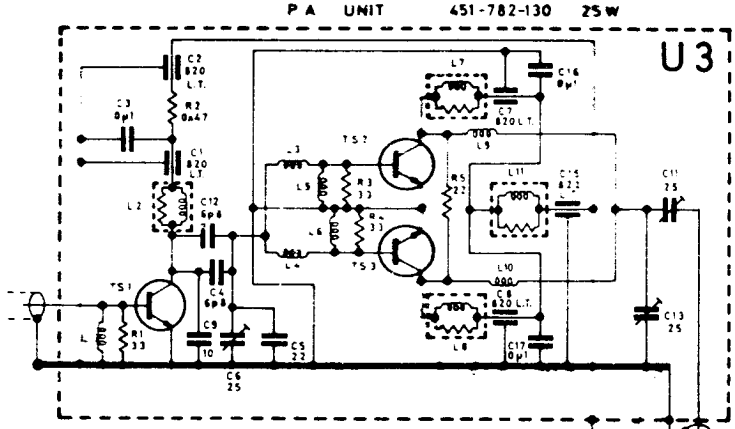
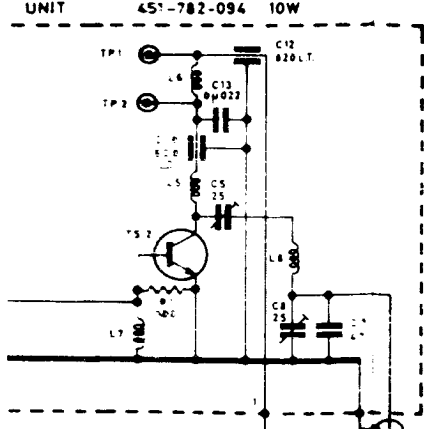

NOTE:
PA Unit U3
451-782-094 is installed in
model A10
451-782-130 is installed in
model A25

13 C2	U14 C4
only on	10μF-10W
5 Watt	40μF-25W

NOTE: All connections between units (U1 to U14) are made via the interwiring card U11.

FM 1680A (70-85 MHz A BAND) CIRCUIT DIAGRAM 450-782-237

U7/TS3	U7/TS4	U7/TS5	U7/TS6	U7/TS7	U9/TS1	U9/TS2
e 0	e 5.1	e 0.4	e 5.8	e 5.8	e 10.6	e 13.8
b 0.7	b 5.7	b 1.1	b 5.8	b 5.8	b 11.4	b 13.3
c 0.05	c 10.9	c 5.8	c 11.4	c 0	c 13.3	c 11.4

Transmitter Alignment and Test Procedure

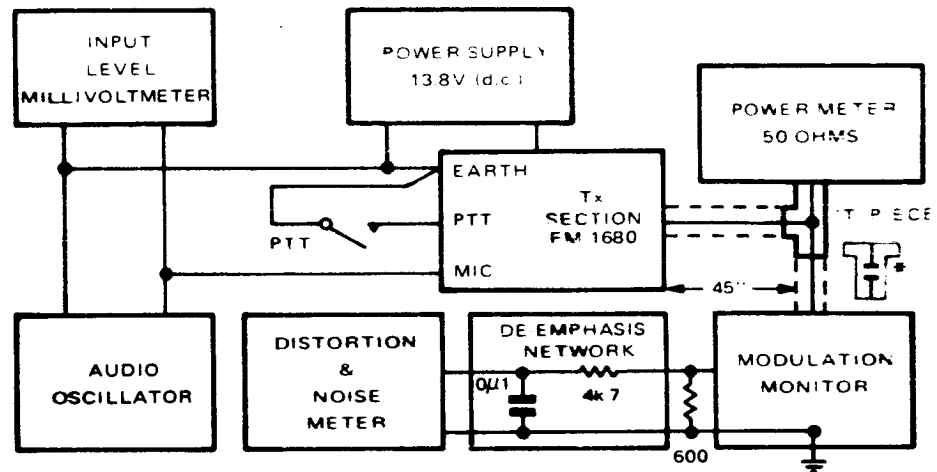

Figure 4

Test Equipment

Equipment having similar characteristics to the items listed below may be used.

- (a) Hum-free Power Supply to give 13.8V d.c. minimum, 5A rating.
- (b) Multimeter – AVO 8
- (c) R.F. Power Meter (50 ohms) – Bird Termaline 612
- (d) Modulation Monitor – Airmec 210A
- (e) Audio Oscillator – Wayne Kerr
- (f) Distortion and Noise Meter – AWA
- (g) VTVM – Philips GM 6009
- (h) De-emphasis Network ($4k7 + 0\mu1$)
- (j) Mismatch piece (15 pF 10W; 10 pF 25W) *
- (k) Resistors – 3 ohm 40 watt; 6 ohm 40 watt; 220 ohm 1 watt; 2k2 ohm 1 watt; 1k ohm 1 watt.

NOTE: All component references are prefixed by the number of the board on which the components are mounted e.g. 2C4 refers to capacitor C4 on board U2.

Preparation

1. Set up the equipment as shown in Figure 4.
2. Set 14RV1 fully anti-clockwise.
3. Ensure that the voltage regulator output (U9 pin 3) is within 11.3V to 11.9V.

Polarity Reversal and Short Circuit Protection (U13)

Remove the transmitter crystal to prevent drive to the PA stage. Set 13RV1 to maximum resistance (slide towards rear of radiotelephone).

10 Watt Unit

1. Connect the 6 ohm, 40 watt resistor in series with the AVO 8 (10A d.c.) between U13 pin 2 and the honeycomb.
2. Operate the PTT and check that the current reading is $\geq 2A$.
3. Connect the AVO 8 (2.5V d.c.) between the collector and emitter of 13TS1. Check that $V_{ce} \leq 0.2V$.
4. If necessary, reduce the resistance of 13RV1 to obtain the figures in paras. 2 and 3.
5. Connect the 220 ohm, 1 watt resistor between U13 pin 5 and U13 pin 3 (earth). Check that the current measured as in para. 2 above is $< 1A$ and that the voltage measured as in para. 3 above is $\geq 8V$.
6. Remove the load resistors and replace the transmitter crystal.

25 Watt Unit

1. Connect the 3 ohm, 40 watt resistor in series with the AVO 8 (10A d.c.) between U13 pin 2 and the honeycomb. AC2-16 127
2. Operate the PTT and check that the current is $\geq 4A$.
3. Connect the AVO 8 (2.5V d.c.) between the collector and emitter of 13TS1. Check that $V_{ce} \leq 0.4V$.
4. If necessary, reduce the resistance of 13RV1 to obtain the figures in paras. 2 and 3.
5. Connect the 220 ohm, 1 watt resistor between U13 pin 5 and U13 pin 3 (earth). Check that the current measured as in para. 2 above is $< 2A$ and that the voltage measured as in para. 3 above is $\geq 8V$.
6. Remove the load resistors and replace the transmitter crystal.

Adjustment of Trimmers

1. With audio off, adjust the following trimmers:

10 Watt Unit

2C8, 2C10, 2C14, 2C16, 2C18, 2C22	—	Maximum capacitance
3C4, 3C5	—	Maximum capacitance
3C2, 3C8	—	Minimum capacitance

25 Watt Unit

2C8, 2C10, 2C14, 2C16, 2C18, 2C22	—	Maximum capacitance
3C1	—	$\frac{1}{2}$ Maximum capacitance
3C14	—	Minimum capacitance
3C8, 3C13, 3C22	—	Maximum capacitance
3C3, 3C20	—	Mid-way

Alignment of Exciter Board (U2)

1. Connect the 1k, 1 watt resistor, in series with the AVO 8 –ve lead, to the chassis.
2. With the AVO 8 (10 mA) +ve lead monitor 2TP1. Tune 2L15, 2L16 for maximum meter reading (app. 2.3 mA).
3. Connect the AVO 8 (1 mA) +ve lead to the +11.4V rail. With the AVO 8 –ve lead, in series with the 1k, 1 watt resistor, monitor 2TP2. Tune 2L17, 2L18 for maximum meter reading (app. 0.6 mA).
4. Tune 2C8 for a dip in the AVO 8 reading (app. 0.5 mA).
5. Connect the AVO 8 –ve lead in series with the 1k, 1 watt resistor, to the chassis. With the AVO 8 (1 mA) +ve lead monitor 2TP3. Tune 2C10 for maximum meter reading (app. 850 μ A).
6. Tune 2C14 for a dip in the AVO 8 reading (app. 750 μ A).
7. Connect the AVO 8 (250 μ A) –ve lead to the chassis and with the AVO 8 +ve lead, in series with the 1k, 1 watt resistor, monitor 2TP4. Tune 2C18 for minimum meter reading (app. 200 μ A).
CAUTION: Beware of false dips.
8. Reduce capacitance of 2C16 to obtain AVO 8 reading of approximately 180 μ A.
9. Tune 2C22 for a dip in the meter reading.
10. Connect AVO 8 (250 μ A) across 3L18. Tune 2C22 to obtain maximum reading.
11. After alignment of PA, readjust 2L15, 2L16 for minimum distortion of 400 Hz modulation.

Alignment of PA Stage

10 Watt Unit

CAUTION: Do not tune for a power output of more than 11 watts.

1. Connect the AVO 8 (50 μ A) across 3L4. Tune 2C22 for maximum reading (app. 5 μ A). Tune 3C2 for maximum reading.
2. Connect the AVO 8 (50 μ A) across 3L6. Tune 3C4 for maximum reading (app. 10 μ A).
3. Tune 3C2 and re-tune 3C4 for maximum reading (app. 33 μ A).
4. Tune 3C5, 3C8 for maximum output power.
5. Connect the AVO 8 (250 μ A) –ve lead to chassis. With the AVO 8 +ve lead in series with the 1k, 1 watt resistor, monitor 2TP4. Re-tune 2C16, 2C8, 2C10, 2C14 for maximum reading.
6. Re-tune 2C18, 2C22, 3C2, 3C4, 3C8, 3C5 in this sequence to obtain maximum output power (11 watts).
7. Reduce output power to 10 – 10.5 watts by reducing capacitance of 3C8 and re-tuning 3C5.

25 Watt Unit

CAUTION: Do not tune for a power output of more than 25.5 watts.

1. Connect the AVO 8 (250 μ A) across 3L18. Tune 3C3 for maximum reading.
2. Connect the AVO 8 (250 μ A) across 3L7. Tune 3C8 for maximum reading.
3. Re-tune 2C18, 2C22, 3C3 for maximum reading.
4. Connect AVO 8 (250 μ A) across 3L17. Tune 3C14 for maximum reading.
5. Remove AVO 8.
6. Tune 3C22, 3C20 alternately for maximum output power.
7. Reduce capacitance of 3C13 by $\frac{1}{4}$ turn and re-tune 3C14, 3C22, 3C20 for maximum output power. Repeat procedure to obtain maximum output power.
8. If output power is <25 watts, increase capacitance of 3C1 and re-tune 3C3, 2C22 for maximum output power. Re-tune 3C8, 3C14, 3C22, 3C20. Repeat the procedure until the output power is 25 to 25.5 watts.

Modulation

1. Check that the test equipment is connected as shown in Figure 4.
2. With the transmitter on and the correct output power indicated, tune the modulation monitor to the correct frequency, adjust the input level and set for frequency modulation.
3. Set 1RV1 fully clockwise.
4. For maximum deviation set the audio oscillator to $3 \text{ kHz} \pm 150 \text{ Hz}$, at an input level of $50 \text{ mV} \pm 5 \text{ mV}$, and adjust 1RV2 to give the following:

Narrow channel separation (N)	–	$5 \text{ kHz} \pm 0.3 \text{ kHz deviation}$
Wide channel separation (NW)	–	$15 \text{ kHz} \pm 0.3 \text{ kHz deviation}$
5. Set the audio oscillator to $1 \text{ kHz} \pm 50 \text{ Hz}$, with an input level of $5 \text{ mV} \pm 0.5 \text{ mV}$.
6. Adjust 1RV1 to give the following:

Narrow channel separation (N)	–	$3.3 \text{ kHz} \pm 0.1 \text{ kHz deviation}$
Wide channel separation (NW)	–	$10 \text{ kHz} \pm 0.3 \text{ kHz deviation}$
7. Recheck para. 4. Deviation should not exceed 5 kHz for N and 15 kHz for NW.
8. Under the conditions set in para. 6 check the following:

Distortion	–	< 5%
Noise	–	More than 50 dB below 3.3 kHz for N More than 50 dB below 10 kHz for NW

Field Test. An alternative method of testing operation and deviation is as follows:

1. Do not connect the audio oscillator; leave the microphone connected.
2. With the transmitter on and the correct output power indicated, tune the modulation monitor to the correct frequency, adjust the input level and set for frequency modulation.
3. With the PTT pressed, speak into the microphone. An average deviation of 3 kHz (N) or 10 kHz (NW) indicates that 1RV1 is set correctly.
4. Whistle into microphone (app. 1 kHz). Deviation of 5 kHz (+0 –0.5 kHz) for N or 15 kHz (+0 –1 kHz) for NW, indicates that 1RV2 is set correctly.

Aerial Mismatch Protection (U14)

1. Remove all test equipment shown in Figure 4 except the Power Supply and Power Meter.
2. Set 14RV1 between the fully anti-clockwise and the centre positions.
3. Connect the AVO 8 (2.5V d.c.) between earth and the monitor point on U14.
4. Operate the PTT, tune 14C5 for minimum reading.
5. Connect the mismatch piece (15 pF 10W; 10 pF 25W) to the free end of the T-piece; this sets up a SWR of approximately 2:1 along the line.
6. Connect the AVO 8 (10V d.c.) between the emitter and collector of 13TS1 on U13.
7. Operate the PTT, adjust 14RV1 to obtain a reading of 4V on the AVO 8.
8. Remove the mismatch piece and check that the output power is restored without the PTT having to be re-operated.

Receiver Alignment and Test Procedure

Test Equipment

Equipment having similar characteristics to the items listed below may be used.

- (a) Hum-free Power Supply to give 13.8V d.c. minimum, 5A rating.
- (b) Multimeter – AVO 8
- (c) VTVM – Philips GM 6009
- (d) Signal Generator – Marconi TF 995/A5
- (e) 455 kHz Generator – Philips PM 5300
- (f) Audio Oscillator – Wayne Kerr
- (g) 10.7 MHz Marker
- (h) Distortion and Noise Meter – AWA
- (j) 6 dB terminating pad – Marconi
- (k) 20 dB attenuator pad – Marconi
- (l) Elec. Capacitor 25 μ F, 25 VW (2 off)
- (m) Resistor – 5 ohm 2 watt

NOTE: All component references are prefixed by the number of the board on which the components are mounted e.g. 2C4 refers to capacitor C4 on board U2.

Preparation

1. Connect the 13.8V Power Supply to the unit. Set the VOLUME control fully clockwise and the MUTE control fully anti-clockwise. Noise should be audible from the loudspeaker. Ensure that the output of the voltage regulator (U9 pin 3) is within 11.3V to 11.9V.

NOTE: Unless otherwise stated all S/N measurements are to be taken at an audio output of 200 mWatts.

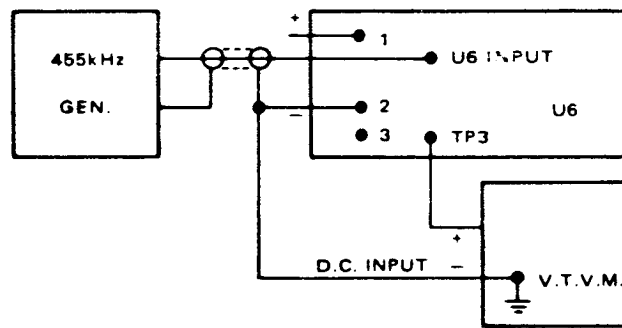

Figure 5

I.F. Alignment (U6)

1. Set up the equipment as shown in Figure 5.
2. Zero beat the 455 kHz signal generator with the 10.7 MHz marker and adjust the output to $300 \mu\text{V}$.
3. With the a.c. probe of the VTVM monitor the voltage at the following points.
 - (a) Junction 6C24/6C26 – tune 6L4 for maximum (app. 5V)
 - (b) 6TP2 – tune 6L3 for maximum (app. 100 mV).
 - (c) 6TP1 – tune 6L2 for maximum (app. 300 mV).
4. Connect the d.c. probe of the VTVM to 6TP3 and tune 6L5 for 0V.
5. To check the discriminator, vary the input frequency by 5 kHz (N) or 15 kHz (NW) and check that the change of output is $\geq 1\text{V}$ (N) or $\geq 2\text{V}$ (NW).

Oscillator Alignment (U5)

1. **Single Channel.** Set 5C7 and 5C8 to minimum capacitance and check that the correct crystal is in the receiver crystal socket.
2. Connect the AVO 8 (10V d.c.) between 5TP1 and the 11.4V +ve rail.
3. Adjust the netting coil slug for maximum voltage reading.
4. Tune 5C7 for minimum voltage reading.
5. Connect AVO 8 (2.5V d.c.) –ve lead to 4TP1 and the +ve lead to 4R5 (top loop).
6. Measure the voltage at 4TP1. Tune 5C8 and re-tune 5C7 alternately for maximum voltage reading.
7. **Multi-channel.** Select highest and lowest frequency crystal in turn. In each case, adjust 5C8 to give equal readings at 4TP1. Adjust coupling 5L2, 5L3 to give a reading of 0.7V–0.9V. This may require re-tuning of 5C8 and 5C7.

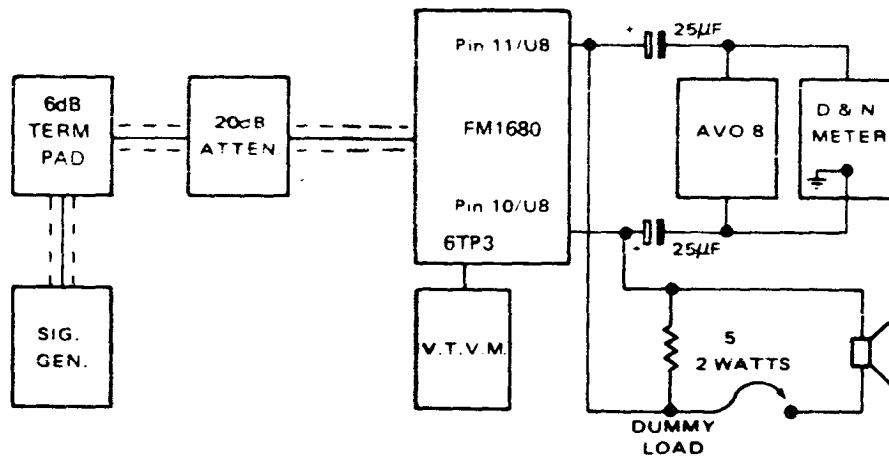

Figure 6

R.F. Alignment (U4)

1. Set up the equipment as shown in Figure 6.
2. Set 4C1, 4C3, 4C6 and 4C10 three turns out from the maximum capacitance position. Set the slug of 4L9 level with the top of the former.
3. Set the signal generator to the receiver channel frequency and adjust the output to give a S/N ratio of approximately 15 dB.
4. Adjust trimmers 4C1, 4C3, 4C6, 4C10 and 4L9 for maximum S/N ratio while gradually reducing the output of the signal generator until a S/N ratio of 32 dB (N) or 40 dB (NW) is obtained with an input of $1 \mu\text{V}$.
5. Increase the output of the signal generator by 10 dB and de-tune 4C3 until the original S/N ratio is obtained.
6. Tune 4C1 for maximum S/N ratio.
7. Tune 4C3 for maximum S/N ratio while decreasing the output of the signal generator to maintain a S/N ratio of 32 dB (N) or 40 dB (NW).
8. Increase the output of the signal generator by 20 dB and de-tune 4C10 until the original S/N ratio is obtained.
9. Tune 4C7 for maximum S/N ratio.
10. Re-tune 4C6, 4C10 while decreasing the output of the signal generator until a S/N ratio of 32 dB (N) or 40 dB (NW) is obtained.

Sensitivity

NOTE: All voltage sensitivity figures are p.d.

1. **Signal/Noise Ratio.** Set the signal generator deviation to 5 kHz (N) or 15 kHz (NW) at 1 kHz with $1 \mu\text{V}$ input to the receiver. Adjust the receiver output to give 200 mWatts (1V across dummy load).
2. Remove audio modulation and check that the S/N ratio is not less than 32 dB (N) or 40 dB (NW).
3. **Image Response.** Set the signal generator to 21.4 MHz above the signal frequency, with 1 kHz modulation at 1.5 kHz (N) or 4.5 kHz (NW) deviation, and an input to the receiver of 8 mV.
4. Adjust the output of the receiver to 200 mWatts. Remove the audio modulation and check that the S/N ratio is not less than 10 dB.

Audio Output and Distortion

1. Set the signal generator to 1 kHz modulation with 3.3 kHz (N) or 10 kHz (NW) deviation.
2. Adjust the receiver input to 5 μV and adjust the VOLUME control to give an output of 2 watts (3.16V across the dummy load).
3. Distortion must be $\leq 10\%$.

Phase Correction

1. Modulate the signal generator with the audio oscillator set to 1 kHz. Set the signal generator modulation deviation to 3 kHz with a receiver input of 5 μV .
2. Adjust the audio output to 0.9V across the dummy load.
3. Set the audio oscillator frequency to 300 Hz. The receiver output should rise by between +7.3 dB and +11.7 dB.
4. Increase the audio oscillator frequency to 1 kHz and check that the receiver output is still 0.9V.
5. Set the oscillator frequency to 3 kHz. Check that the output across the dummy load is between -8.7 dB and -15 dB.

Squelch

1. Remove the dummy load and re-connect the loudspeaker.
2. Set the MUTE control so that the receiver is just squelched (loose squelch).
3. Set the signal generator for a modulation of 1 kHz at 5 kHz (N) or 15 kHz (NW) deviation.
4. Gradually increase the output of the signal generator until the signal is just audible as the carrier is turned on. Note the required signal level.
5. Set the MUTE control fully clockwise and increase the output of the signal generator until the receiver output becomes audible. Note the required level (tight squelch).
6. Limits:
 - Loose squelch $< 0.4 \mu\text{V}$
 - Tight squelch $\geq 2 \times$ signal required for loose squelch but $< 4 \mu\text{V}$.

Mod. Amp. Board U1

451-782-021

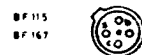
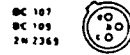
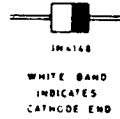
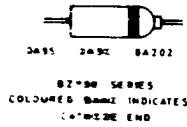
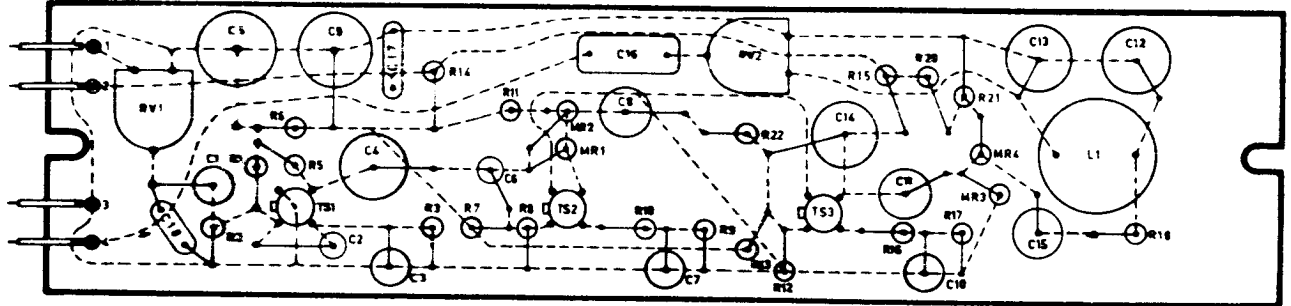
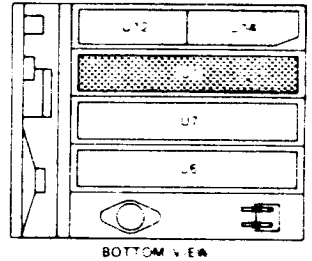

Parts List

CAPACITORS

Ref.	Value	Type	Tol.%	V.W.	Part No.
C1	4 μ F	E	+50 -10	40	055-237-540
C2	2200pF	C/T	+50 -20	500	056-154-222
C3	32 μ F	E	+50 -10	4	055-232-632
C4	4700pF	P/e	\pm 10	400	053-253-247
C5	80 μ F	E	+50 -10	25	055-236-680
C6	0.1 μ F	E	+100 -10	64	055-238-464
C7	32 μ F	E	+50 -10	4	055-232-632
C8	40 μ F	E	+50 -10	16	055-235-640
C9	80 μ F	E	+50 -10	25	055-236-680
C10	32 μ F	E	+50 -10	4	055-232-632
C11	25 μ F	E	+50 -10	25	055-236-625
C12	0.1 μ F	P/e	\pm 10	160	053-248-310
C13	0.1 μ F	P/e	\pm 10	160	053-248-310
C14	0.1 μ F	P/e	\pm 10	160	053-248-312
C15	25 μ F	E	+50 -10	25	055-236-625
C16	0.1 μ F	P/e	\pm 20	250	054-061-410
C17	0.1 μ F	C/D	\pm 20	25	054-173-410
C18	0.1 μ F	C/D	+80 -20	25	056-173-310

RESISTORS

Ref.	Value	Type	Tol.%	W	Part No.
R1	39k	Carb.	\pm 5	$\frac{1}{4}$	062-023-339
R2	15k	Carb.	\pm 5	$\frac{1}{4}$	062-023-315
R3	1k	Carb.	\pm 5	$\frac{1}{4}$	062-023-210
R5	2k2	Carb.	\pm 5	$\frac{1}{4}$	062-023-222
R6	220	Carb.	\pm 5	$\frac{1}{4}$	062-023-122
R7	39k	Carb.	\pm 5	$\frac{1}{4}$	062-023-339
R8	15k	Carb.	\pm 5	$\frac{1}{4}$	062-023-315
R9	1k	Carb.	\pm 5	$\frac{1}{4}$	062-023-210
R10	22	Carb.	\pm 5	$\frac{1}{4}$	062-023-022
R11	2k2	Carb.	\pm 5	$\frac{1}{4}$	062-023-222
R12	6k8	Carb.	\pm 5	$\frac{1}{4}$	062-023-268
R13	22k	Carb.	\pm 5	$\frac{1}{4}$	062-023-322
R14	220	Carb.	\pm 5	$\frac{1}{4}$	062-023-122
R15	2k2	Carb.	\pm 5	$\frac{1}{4}$	062-023-222
R16	10	Carb.	\pm 5	$\frac{1}{4}$	062-023-010
R17	470	Carb.	\pm 5	$\frac{1}{4}$	062-023-147
R18	3k3	Carb.	\pm 5	$\frac{1}{4}$	062-023-233
R20	4k7	Carb.	\pm 5	$\frac{1}{4}$	062-023-247
R21	470	Carb.	\pm 5	$\frac{1}{4}$	062-023-147
R22	3k9	Carb.	\pm 5	$\frac{1}{4}$	062-023-239

SEMICONDUCTORS

Ref.	Description	Part No.
MR1	Diode Sil. OA202	079-111-001
MR2	Diode Sil. OA202	079-111-001
MR3	Diode Sil. 1N4148	079-124-001
MR4	Diode Sil. 1N4148	079-124-001
TS1	Trans. Sil. BC107	078-101-007
TS2	Trans. Sil. BF115	078-104-006
TS3	Trans. Sil. BF115	078-104-006

RESISTORS VARIABLE

Ref.	Description	Part No.
RV1	2k2 Min Trimmer \pm 20% 0.1 Watt	068-072-008
RV2	10k Min Trimmer \pm 20% 0.1 watt	068-072-007

CHOKES, COILS AND INDUCTORS

Ref.	Description	Part No.
L1	Audio Filter Coil	451-782-039

Exciter Board U2

451-782-022

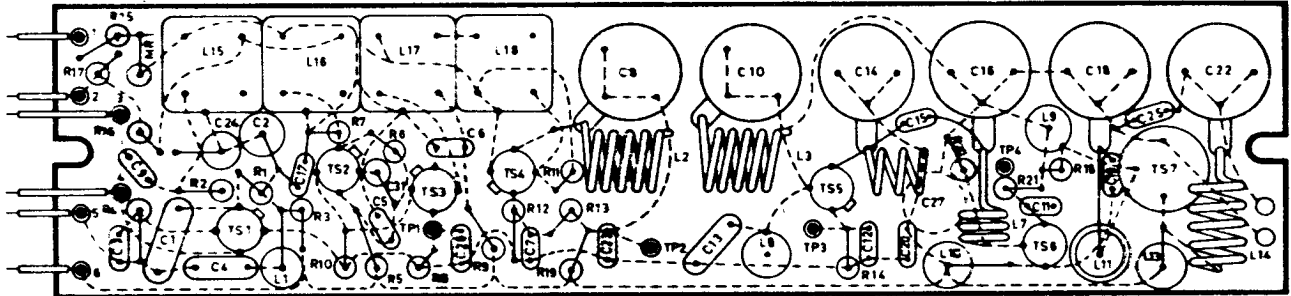
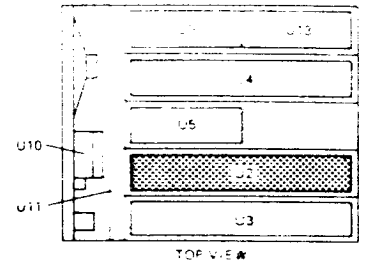

COLLECTOR
INTERIALLY
CONNECTED
TO THE CASE



BZY88 SERIES
COLOURED BAND INDICATES
CATHODE END

BC 107
BC 108
2N 2369



BF 115
BF 167



Parts List

CAPACITORS						RESISTORS						CHOKES, COILS AND INDUCTORS		
Ref.	Value	Type	Tol. %	V.W.	Part No.	Ref.	Value	Type	Tol. %	W	Part No.	Ref.	Description	Part No.
C1	120pF	C/D	+10	500	053-134-112	R1	18k	Carb.	+5	¼	062-023-318	L1	R.F. Choke 10µH ±10%	042-610-501
C2	10µF	E	+50	16	055-235-610	R2	15k	Carb.	±5	¼	062-023-315	L2	Second Doubler Coil	450-782-020
			-10			R3	150	Carb.	±5	¼	062-023-115	L3	Second Doubler Coil	450-782-118
C3	0.001	C/D	+80	25	056-173-310	R4	2k2	Carb.	+5	¼	062-023-222	L6	Third Doubler Coil	450-782-021
			-10			R5	100	Carb.	±5	¼	062-023-110	L7	Third Doubler Coil	450-782-022
C4	22pF	C/D	+2%	500	051-124-022	R6	47k	Carb.	±5	¼	062-023-347	L8	R.F. Choke	450-734-093
C5	0.001	C/D	+80	25	056-173-310	R7	15k	Carb.	+5	¼	062-023-315	L9	R.F. Choke	450-734-093
			-10			R8	330	Carb.	±5	¼	062-023-133	L10	R.F. Choke 2µH	042-522-501
C6	0.001	C/D	+80	25	056-173-310	R9	100	Carb.	±5	¼	062-023-110	L11	Driver Input Coil	450-782-023
			-10			R10	1k	Carb.	+5	¼	062-023-210	L13	R.F. Choke	042-451-501
C7	0.001	C/D	+80	25	056-173-310	R11	100	Carb.	±5	¼	062-023-110	L14	Driver Output Coil	450-782-024
			-10			R12	1k	Carb.	±5	¼	062-023-210	L15	Mod. Coil Assy. 1	451-782-042
C8	25pF	Air Trimmer			058-051-602	R13	33k	Carb.	+5	¼	062-023-333	L16	Mod. Coil Assy. 2	451-782-043
C9	0.0022	C/D	+80	25	056-173-322	R14	47	Carb.	+5	¼	062-023-047	L17	First Doubler Coil	451-782-044
			-10			R15	2k2	Carb.	±5	¼	062-023-222	L18	First Doubler Coil	451-782-045
C10	25pF	Air Trimmer			058-051-602	R16	47k	Carb.	+5	¼	062-023-347			
C11	560pF	C/D	±10	500	053-164-156	R17	100k	Carb.	±5	¼	062-023-410			
C12	560pF	C/D	±10	500	053-164-156	R18	330	Carb.	±5	¼	062-023-133			
C13	39pF	C/D	±0p25	500	051-134-039	R19	150	Carb.	±5	¼	062-023-115			
C14	25pF	Air Trimmer			058-051-602	R20	150	Carb.	±5	¼	062-023-115			
C15	3.3pF	C/D	±0p25	500	051-124-933	R21	10	Carb.	±5	¼	062-023-010			
C16	25pF	Air Trimmer			058-051-602									
C17	0.001	C/D	+80	25	056-173-310									
			-10											
C18	25pF	Air Trimmer			058-051-602									
C19	15pF	C/D	+2%	500	051-124-015									
C20	0.001	C/D	+80	25	056-173-310									
			-10											
C21	10µF	E	+50	16	055-235-610									
			-10											
C22	25pF	Air Trimmer			058-051-602									
C23	0.001	C/D	+80	25	056-173-310									
			-10											
C24	470pF	P/s	+5	100	052-017-147									
C25	15pF	C/D	±2%	500	051-124-015									
C26	0.001	C/D	+80	25	056-173-310									
			-10											
C27	27pF	C/D	±2.5%	500	051-134-027									

SEMICONDUCTORS		
Ref.	Description	Part No.
MR1	Diode Zener BZY88/C5V6	079-401-007
TS1	Trans. Sil. BF115	078-104-006
TS2	Trans. Sil. BF115	078-104-006
TS3	Trans. Sil. BF115	078-104-006
TS4	Trans. Sil. BF115	078-104-006
TS5	Trans. Sil. 2N2369	078-101-011
TS6	Trans. Sil. 2N2369	078-101-011
TS7	Trans. Sil. 2N3563	078-509-001

P. A. Unit U3

451-782-023 C/10N & C/10NW

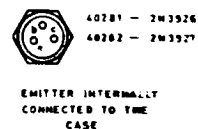
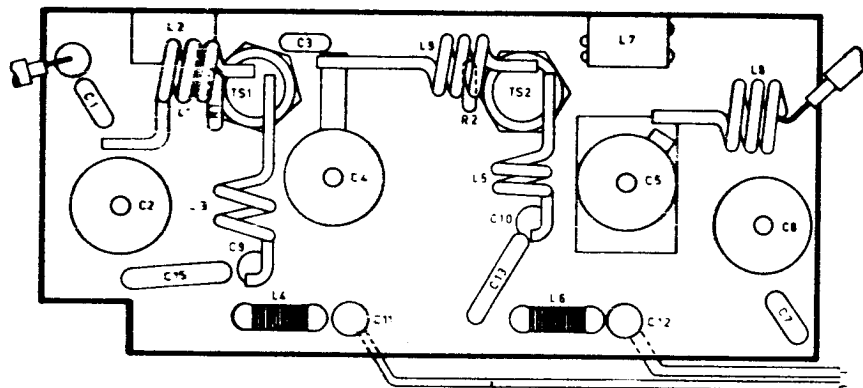
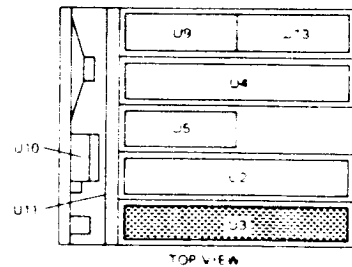

Parts List

CAPACITORS

Ref.	Value	Type	Tol. %	V.W.	Part No.
C1	4.7pF	C/D	±0p25	500	051-124-947
C2	25pF	Air Trimmer			058-051-602
C3	4.7pF	C/D	±0p25	500	051-124-947
C4	25pF	Air Trimmer			058-051-602
C5	25pF	Air Trimmer			058-051-602
C7	10pF	C/D	±0p25	500	051-124-010
C8	25pF	Air Trimmer			058-051-602
C9	820pF	L/T	+100 -20	350	056-402-001
C10	820pF	L/T	+100 -20	350	056-402-001
C11	820pF	L/T	+100 -20	350	056-402-001
C12	820pF	L/T	+100 -20	350	056-402-001
C13	0μ1	C/D	±20	25	054-173-410
C15	0μ1	C/D	±20	25	054-173-410

RESISTORS

Ref.	Value	Type	Tol. %	W	Part No.
R1	47	Carb.	±5	¼	062-023-047
R2	220	Carb.	±5	¼	062-023-122

SEMICONDUCTORS

Ref.	Description	Part No.
TS1	Trans. Sil. 2N3926	078-110-001
TS2	Trans. Sil. 2N3927	078-110-002

CHOKES, COILS AND INDUCTORS

Ref.	Description	Part No.
L1	Driver Input Coil	450-782-030
L2	R.F. Choke (Ferroxcube Bead)	450-734-093
L3	Driver Collector Coil	450-782-031
L4	Metering Coil	451-782-052
L5	PA Collector Coil	450-782-032
L6	Metering Coil	451-782-123
L7	R.F. Choke (Ferroxcube Bead)	450-734-093
L8	PA Tank Coil	450-782-033
L9	PA Input Coil	450-782-034

P.A. Unit U3

451-782-117 C/25N & C/25NW

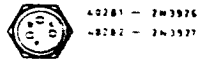

EMITTER INTERNALLY
CONNECTED TO THE
CASE

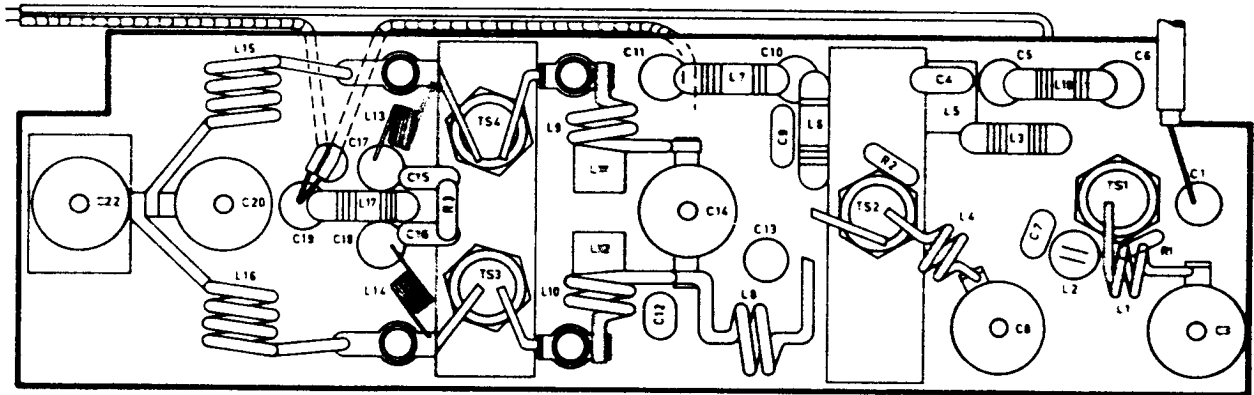
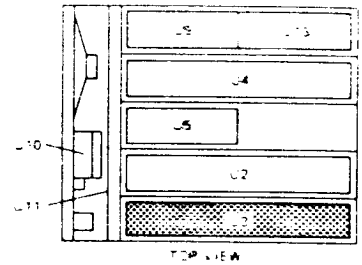

Parts List

CAPACITORS

Ref.	Value	Type	Tol.%	V.W.	Part No.
C1	9pF	Ceramic Trimmer			058-020-901
C3	25pF	Air Trimmer			058-051-602
C4	0.0047	C/D	+80 -20	25	056-173-347
C5	820pF	L/T	+100 -20	350	056-402-001
C6	820pF	L/T	+100 -20	350	056-402-001
C7	10pF	C/D	±0p25	500	051-124-010
C8	25pF	Air Trimmer			058-051-602
C9	0.0047	C/D	+80 -20	25	056-173-347
C10	820pF	L/T	+100 -20	350	056-402-001
C11	820pF	L/T	+100 -20	350	056-402-001
C12	10pF	C/D	±0p25	500	051-124-010
C13	9pF	Ceramic Trimmer			058-020-901
C14	25pF	Air Trimmer			058-051-602
C15	0.001	C/D	+80 -20	500	056-173-310
C16	0.001	C/D	+80 -20	500	056-173-310
C17	820pF	L/T	+100 -20	350	056-402-001
C18	820pF	L/T	+100 -20	350	056-402-001
C19	820pF	L/T	+100 -20	350	056-402-001
C20	25pF	Air Trimmer			058-051-602
C22	25pF	Air Trimmer			058-051-602

RESISTORS

Ref.	Value	Type	Tol.%	W	Part No.
R1	220	Carb.	±5	¼	062-023-122
R2	100	Carb.	±5	¼	062-023-110
R3	22	Carb.	±5	¼	062-023-022

SEMICONDUCTORS

Ref.	Description	Part No.
TS1	Trans. Sil. 2N3926	078-110-001
TS2	Trans. Sil. 2N3927	078-110-002
TS3	Trans. Sil. 2N3927	078-110-002
TS4	Trans. Sil. 2N3927	078-110-002

CHOKES, COILS AND INDUCTORS

Ref.	Description	Part No.
L1	Driver Input Coil	450-782-152
L2	R.F. Choke (Ferroxcube Bead)	450-734-093
L3	R.F. Choke	451-782-121
L4	Driver Input Coil	450-782-153
L5	R.F. Choke (Ferroxcube Bead)	450-734-093
L6	R.F. Choke	451-782-122
L7	Metering Coil	451-782-123
L8	PA Input Coil, 1st Section	450-782-154
L9	PA Input Coil, 2nd Section	450-782-155
L10	PA Input Coil, 2nd Section	450-782-156
L11	R.F. Choke (Ferroxcube Bead)	450-734-093
L12	R.F. Choke (Ferroxcube Bead)	450-734-093
L13	PA Choke	450-782-158
L14	PA Choke	450-782-158
L15	PA Tank Coil	450-782-157
L16	PA Tank Coil	450-782-159
L17	Metering Coil	451-782-124
L18	Metering Coil	451-782-123

R.F. Board U4

451-782-024 C/10N & C/25N

451-782-132 C/10NW & C/25NW

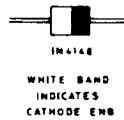
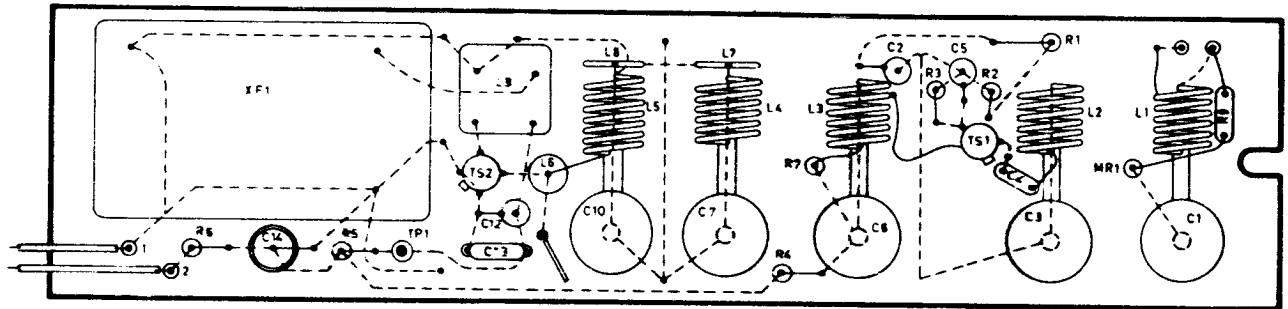
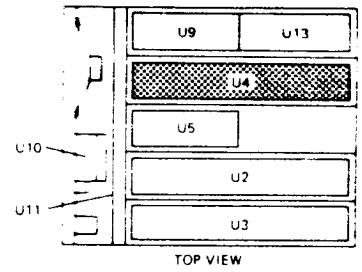

BF115
BF167



Parts List

451-782-024 C/10N & C/25N

CAPACITORS

Ref.	Value	Type	Tol.%	V.W.	Part No.
C1	25pF	Air Trimmer	200		058-051-601
C2	1000pF	C/T	+50 -20	500	056-164-210
C3	25pF	Air Trimmer	200		058-051-601
C4	3p3	C/D	+0p25	500	051-124-933
C5	1000pF	C/T	+50 -20	500	056-164-210
C6	25pF	Air Trimmer	200		058-051-601
C7	25pF	Air Trimmer	200		058-051-601
C10	25pF	Air Trimmer	200		058-051-601
C12	1000pF	C/T	+50 -20	500	056-164-210
C13	0.001	C/D	+80 -20	25	056-173-310
C14	40μF	E	+50 -10	16	055-235-640

RESISTORS

Ref.	Value	Type	Tol.%	W	Part No.
R1	3k9	Carb.	±5	¼	062-023-239
R2	1k	Carb.	±5	¼	062-023-210
R3	470	Carb.	±5	¼	062-023-147
R4	100	Carb.	±5	¼	062-023-110
R5	1k	Carb.	±5	¼	062-023-210
R6	100	Carb.	±5	¼	062-023-110
R7	10k	Carb.	±5	¼	062-023-310

SEMICONDUCTORS

Ref.	Description	Part No.
MR1	Diode Sil. 1N4148	079-124-001
TS1	Trans. Sil. BF167	078-104-005
TS2	Trans. Sil. BF115	078-104-006

CHOKES, COILS AND INDUCTORS

Ref.	Description	Part No.
L1	Aerial Coil	450-782-042
L2	R.F. Signal Coil	450-782-043
L3	R.F. Collector Coil	450-782-044
L4	R.F. Signal Coil	450-782-043
L5	R.F. Signal Coil	450-782-043
L6	Choke 1μH ±10%	042-510-501
L7	Coupling Coil	450-782-045
L8	Coupling Coil	450-782-045
L9	I.F. Input Assy.	451-782-060

CRYSTAL FILTER

Ref.	Description	Part No.
XL-F	Crystal Filter - Narrow Band	451-782-059

451-782-132 C/10NW & C/25NW

Components as for 451-782-024, with the following exceptions.

Ref.	Description	Part No.
L9	IF Input Assy.	451-782-160
XL-F	Crystal Filter - Wide Band	451-782-141

Oscillator Board U5

451 - 782 - 025

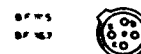
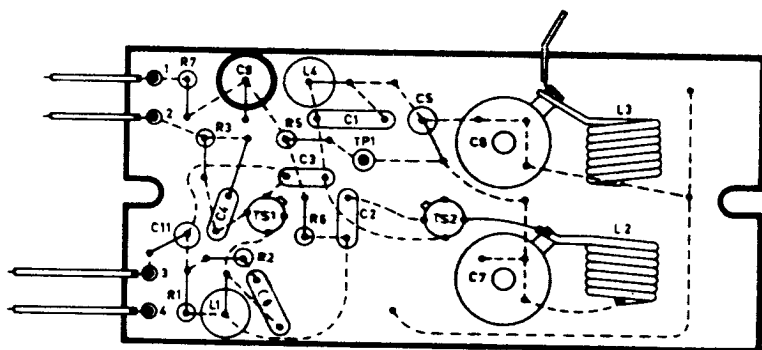
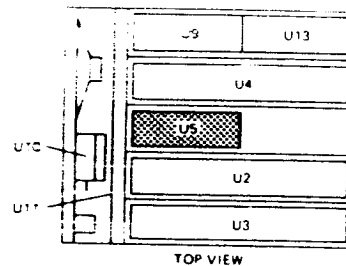

Parts List

CAPACITORS

Ref.	Value	Type	Tol. %	V.W.	Part No.
C1	68pF	C/T	±3	70	051-326-068
C2	0.001	C/D	+80 -20	25	066-173-310
C3	1000pF	C/D	±10	500	053-164-210
C4	0.01	P/e	±20	250	054-061-410
C5	1000pF	C/T	±10	500	056-164-210
C6	10pF	C/P	±0p5	63	051-076-010
C7	10pF	Air Trimmer			058-051-001
C8	10pF	Air Trimmer			058-051-001
C9	40µF	E	+50 -10	16	055-235-640
C10	1.8pF	C/D	±2	60	051-076-027
C11	120pF	C/P	±2	63	051-256-112

RESISTORS

Ref.	Value	Type	Tol. %	W	Part No.
R1	27k	Carb.	±5	×	062-023-327
R2	10k	Carb.	±5	×	062-023-310
R3	680	Carb.	±5	×	062-023-168
R5	1k	Carb.	±5	×	062-023-210
R6	270	Carb.	±5	×	062-023-127
R7	100	Carb.	±5	×	062-023-110

SEMICONDUCTORS

Ref.	Description	Part No.
TS1	Trans. Sil. BF 115	078-104-006
TS2	Trans. Sil. BF 115	078-104-006

CHOKES, COILS AND INDUCTORS

Ref.	Description	Part No.
L1	R.F. Choke 4µ7 ±10%	042-547-501
L2	Tripler Coil	450-782-052
L3	Tripler Coil	450-782-052
L4	R.F. Choke 0.47 ±10%	042-447-501

I.F. Board U6

451-782-026 C/10N & C/25N

451-782-133 C/10NW & C/25NW

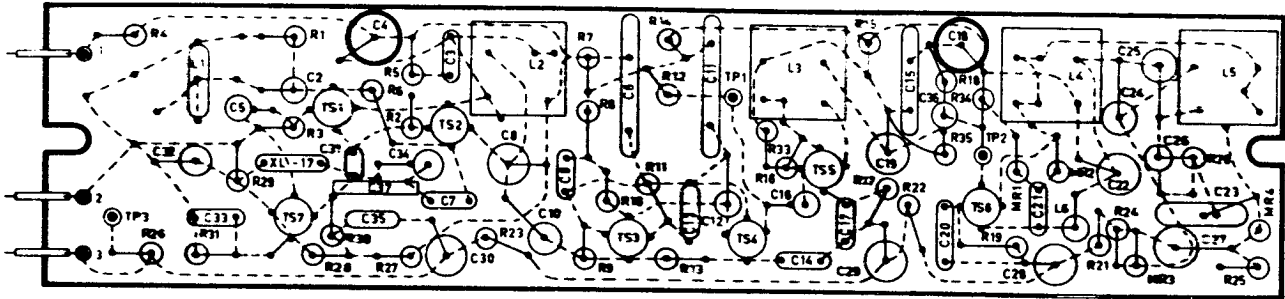
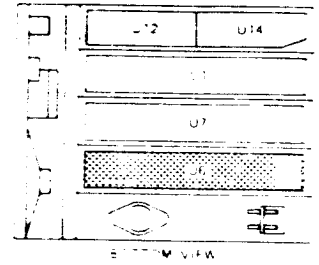
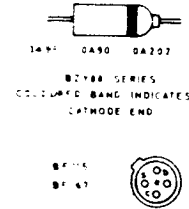

Parts List

451-782-026 C/10 N & C/25 N

CAPACITORS

Ref.	Value	Type	Tol.%	V.W.	Part No.
C2	1000pF	C/T	+50 -20	500	056-164-210
C3	0.001	C/D	+80 -20	25	056-173-310
C4	40µF	E	+50 -10	16	055-235-640
C5	1000pF	C/T	+50 -20	500	056-164-210
C6	0.022	C/D	+80 -20	25	056-173-422
C7	0.001	C/D	+80 -20	25	056-173-310
C8	2700pF	P/s	+2	125	051-017-227
C9	0.001	C/D	+80 -20	25	056-173-310
C10	270pF	P/s	+20	100	054-017-127
C11	0.022	C/D	+80 -20	25	056-173-422
C12	1000pF	C/T	+50 -20	500	056-164-210
C13	0.001	C/D	+80 -20	25	056-173-310
C14	0.0047	C/D	+80 -20	25	056-173-347
C15	0.01	C/D	+80 -20	25	056-173-410
C16	1000pF	C/T	+50 -20	500	056-164-210
C17	0.001	C/D	+80 -20	25	056-173-310
C18	40µF	E	+50 -10	16	055-235-640
C19	2700pF	P/s	+2	125	051-017-227
C20	0.01	C/D	+80 -20	25	056-173-410
C21	0.001	C/D	+80 -20	25	056-173-310
C22	1800pF	P/s	+2	125	051-017-218
C23	150pF	S/M	+2	500	051-424-115
C24	470pF	P/s	+5	100	052-017-147
C25	470pF	P/s	+5	100	052-017-147
C26	47pF	C.P	+2	63	051-186-047
C27	680pF	P/s	+20	100	054-017-168

C28	680pF	P/s	+20	100	054-017-168
C29	680pF	P/s	+20	100	054-017-168
C30	680pF	P/s	+20	100	054-017-168
C31	3p3	C/D	+0p25	500	051-124-933
C32	470pF	P/s	+20	100	054-017-147
C33	0.001	C/D	+80 -20	25	056-173-310
C34	18pF	C/P	+2	63	051-076-018
C35	0.001	C/D	+80 -20	25	056-173-310
C36	33pF	C/D	+2	63	051-186-033
C37	6p8	C/T	+0p5	500	051-194-968

RESISTORS

Ref.	Value	Type	Tol.%	W	Part No.
R1	3k3	Carb.	+5	×	062-023-233
R2	470	Carb.	+5	×	062-023-147
R3	3k3	Carb.	+5	×	062-023-233
R4	100	Carb.	+5	×	062-023-110
R5	3k9	Carb.	+5	×	062-023-239
R6	3k3	Carb.	+5	×	062-023-233
R7	100	Carb.	+5	×	062-023-110
R8	3k3	Carb.	+5	×	062-023-233
R9	1k5	Carb.	+5	×	062-023-215
R10	1k	Carb.	+5	×	062-023-210
R11	1k5	Carb.	+5	×	062-023-215
R12	1k2	Carb.	+5	×	062-023-212
R13	1k5	Carb.	+5	×	062-023-215
R14	100	Carb.	+5	×	062-023-110
R15	2k2	Carb.	+5	×	062-023-222
R16	3k3	Carb.	+5	×	062-023-233
R17	1k	Carb.	+5	×	062-023-210
R18	4k7	Carb.	+5	×	062-023-247
R19	680	Carb.	+5	×	062-023-168
R21	680	Carb.	+5	×	062-023-168
R22	680	Carb.	+5	×	062-023-168
R23	680	Carb.	+5	×	062-023-168
R24	33k	Carb.	+5	×	062-023-333
R25	33k	Carb.	+5	×	062-023-333
R26	82k	Carb.	+5	×	062-023-382
R27	100	Carb.	+5	×	062-023-110
R28	10k	Carb.	+5	×	062-023-310
R29	2k7	Carb.	+5	×	062-023-227
R30	1k8	Carb.	+5	×	062-023-218
R31	1k5	Carb.	+5	×	062-023-215
R33	6k8	Carb.	+5	×	062-023-268
R34	4k7	Carb.	+5	×	062-023-247
R35	6k8	Carb.	+5	×	062-023-268

SEMICONDUCTORS

Ref.	Description	Part No.
MR1	Diode Ger. 0A90	079-212-001
MR2	Diode Ger. 0A90	079-212-001
MR3	Diode Ger. 0A90	079-212-001
MR4	Diode Ger. 0A90	079-212-001
TS1	Trans. Sil. BF 115	078-104-006
TS2	Trans. Sil. BF 115	078-104-006
TS3	Trans. Sil. BF 115	078-104-006
TS4	Trans. Sil. BF 115	078-104-006
TS5	Trans. Sil. BF 115	078-104-006
TS6	Trans. Sil. BF 115	078-104-006
TS7	Trans. Sil. BF 115	078-104-006

CHOKES, COILS AND INDUCTORS

Ref.	Description	Part No.
L1	R.F. Choke 10µH ±10%	042-610-501
L2	IF Coil 455kHz	451-782-064
L3	IF Coil 455kHz	451-782-065
L4	IF Coil 455kHz	451-782-066
L5	Discriminator Coil 455kHz	451-782-067
L6	Choke 1mH	042-810-501

CRYSTAL

Ref.	Description	Part No.
XL-M	2nd Osc. Crystal	450-782-061

451-782-133 C/10 NW & C/25 NW

Components as for 451-782-026 with the following exceptions:

CAPACITORS

Ref.	Value	Type	Tol.%	V.W.	Part No.
C10	470pF	P/s	+20	100	054-017-147
C36	1000pF	C/D	+10	500	053-164-210

RESISTORS

Ref.	Value	Type	Tol.%	W	Part No.
R20	22k	Carb.	+5	.	062-023-322
R36					NIL

Audio Board U7

451-782-027 C/10N & C/25N

451-782-134 C/10NW & C/25NW

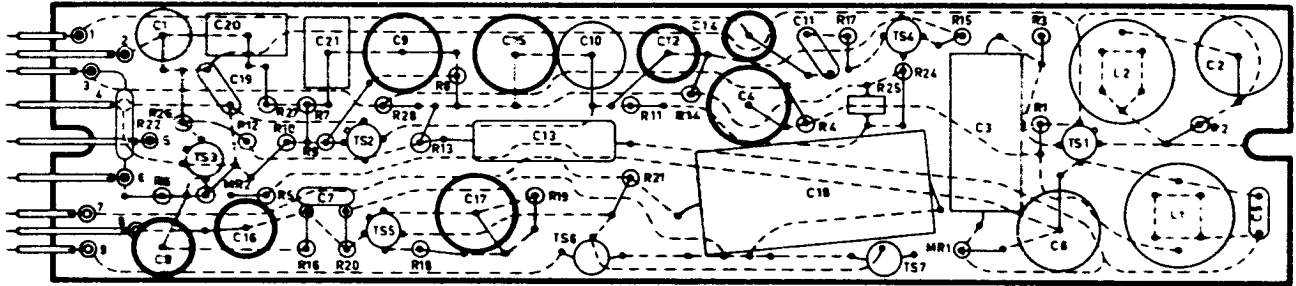
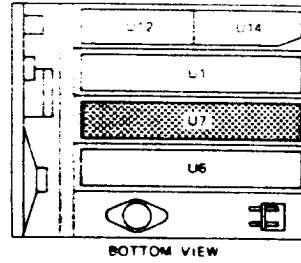

Parts List

451-782-027 C/10 N & C/25 N CAPACITORS

Ref.	Value	Type	Tol.%	V.W.	Part No.
C1	2700pF	P/e	+2	125	051-017-227
C2	0.012	P/e	+10	160	053-248-412
C3	1μ5	P/e	+10	100	053-057-515
C4	125μF	E	+50	16	055-000-003
			-10		
C5	330pF	C/D	+10	500	053-164-133
C6	0.015	P/e	+10	160	053-248-415
C7	0.001	C/D	+80	25	056-173-310
			-20		
C8	10μF	E	+50	16	055-235-610
			-10		
C9	125μF	E	+50	16	055-000-003
			-10		
C10	0.015	P/e	+10	160	053-248-315
C11	1000pF	C/D	+10	500	053-164-210
C12	40μF	E	+50	16	055-235-640
			-10		
C13	64μF	E	+50	10	055-234-664
			-10		
C14	40μF	E	+50	16	055-235-640
			-10		
C15	125μF	E	+50	16	055-000-003
			-10		
C16	40μF	E	+50	16	055-235-640
			-10		
C17	125μF	E	+50	16	055-000-003
			-10		
C18	330μF	E	+20	6.3	055-233-733
C19	500pF	C/D	+10	500	053-164-156
C20	0.022	P/e	+10	100	053-057-422
C21	0.022	P/e	+10	100	053-057-422

RESISTORS

Ref.	Value	Type	Tol.%	W	Part No.
R1	33k	Carb.	±5	×	062-023-333
R2	6k8	Carb.	±5	×	062-023-268
R3	330	Carb.	±5	×	062-023-133
R4	100	Carb.	±5	×	062-023-110
R5	4k7	Carb.	±5	×	062-023-247
R6	10k	Carb.	±5	×	062-023-310
R7	3k9	Carb.	±5	×	062-023-239
R8	220	Carb.	±5	×	062-023-122
R9	47k	Carb.	±5	×	062-023-347
R10	10k	Carb.	±5	×	062-023-310
R11	1k5	Carb.	±5	×	062-023-215
R12	330	Carb.	±5	×	062-023-133
R13	56k	Carb.	±5	×	062-023-356
R14	18k	Carb.	±5	×	062-023-318
R15	22k	Carb.	±5	×	062-023-322
R16	1k5	Carb.	±5	×	062-023-215
R17	2k2	Carb.	±5	×	062-023-222
R18	10	Carb.	±5	×	062-023-010
R19	47	Carb.	±5	×	062-023-047
R20	5k6	Carb.	±5	×	062-023-256
R21	680	Carb.	±5	×	062-023-168
R22	68k	Carb.	±5	×	062-023-368
R24	2k7	Carb.	±5	×	062-023-227
R25	470	Thermistor	±20%		064-104-147
R26	47k	Carb.	±5	×	062-023-347
R27	12k	Carb.	±5	×	062-023-312
R28	100	Carb.	±5	×	062-023-110

SEMICONDUCTORS

Ref.	Description	Part No.
MR1	Diode Sil. 1N4148	079-124-001
MR2	Diode Ger. 0A90	079-212-001
TS1	Trans. Sil. BF115	078-104-006
TS2	Trans. Sil. BF115	078-104-006
TS3	Trans. Sil. BC109	078-101-009
TS4	Trans. Sil. BF115	078-104-006
TS5	Trans. Sil. BC107	078-101-007
TS6	Trans. Sil. Matched Pair	078-000-001
TS7		

451-782-134 C/10 NW & C/25 NW

Components as for 451-782-027 with the following exceptions:

CAPACITORS

Ref.	Value	Type	Tol.%	V.W.	Part No.
C5	3900pF	C/D	+10	500	053-164-239
C19	1000pF	C/D	+10	500	053-164-210

RESISTORS

Ref.	Value	Type	Tol.%	W	Part No.
R22	150k	Carb.	±5	×	062-023-415

CHOKES, COILS AND INDUCTORS

Ref.	Description	Part No.
L1	Peaking Inductor	451-782-073
L2	Peaking Inductor	451-782-073

Front Panel Assembly U8

451-782-028

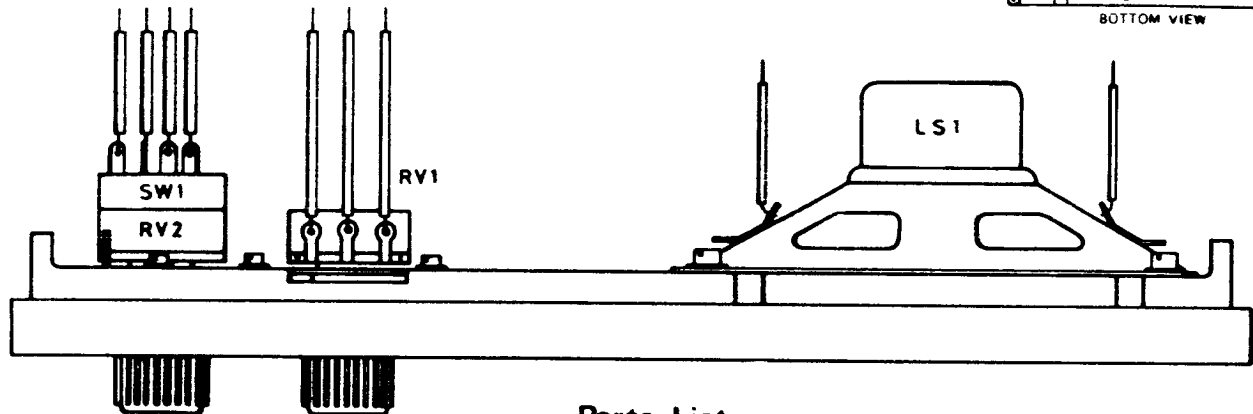
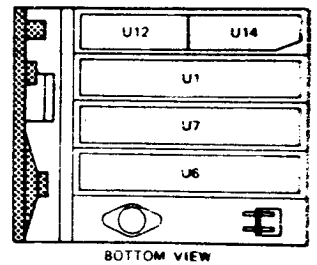

Parts List

RESISTORS VARIABLE

Ref.	Description	Part No.
RV1	Pot'meter 5k \pm 20% 1/2 Watt	068-042-002
RV2	Pot'meter and DPST switch	068-043-001
SW1		

LOUDSPEAKER

Ref.	Description	Part No.
LS1	Loudspeaker 5 ohm (4 in. x 2 1/4 in.) (10.16cms x 7cms)	450-782-063
	Speaker Gauze	450-782-060

Voltage Regulator Board U9

451-782-029

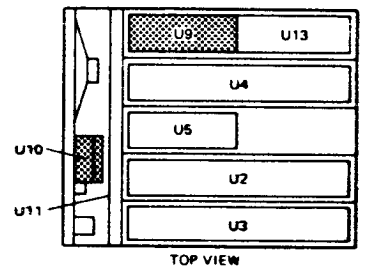
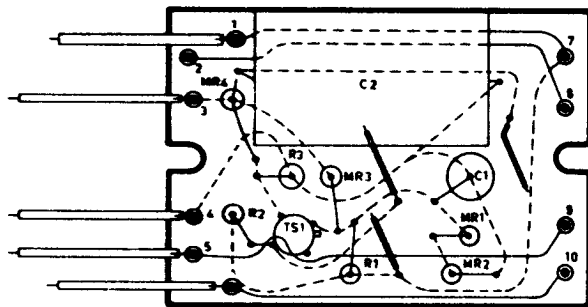

WHITE BAND
INDICATES
CATHODE END



BZY88 SERIES
COLOURED BAND INDICATES
CATHODE END

Parts List

CAPACITORS

Ref.	Value	Type	Tol.%	V.W.	Part No.
C1	25 μ F	E	+50 -10	25	055-236-625
C2	640 μ F	E	+50 -10	16	055-236-764

RESISTORS

Ref.	Value	Type	Tol.%	W	Part No.
R1	560	Carb.	\pm 5	1/4	062-023-156
R2	150	Carb.	\pm 5	1/4	062-023-115
R3	680	Carb.	\pm 5	1/4	062-024-158

SEMICONDUCTORS

Ref.	Description	Part No.
MR1	Diode Sil. BZY 88/C4V7	079-401-005
MR2	Diode Sil. BZY 88/C6V8	079-401-008
MR3	Diode Sil. 1N4148	079-124-001
MR4	Diode Sil. 1N4148	079-124-001
TS1	Trans. Sil. BF115	078-104-006
TS2	Trans. Germ. ASZ16	078-803-004

Crystal Kit U10S

451-782-030

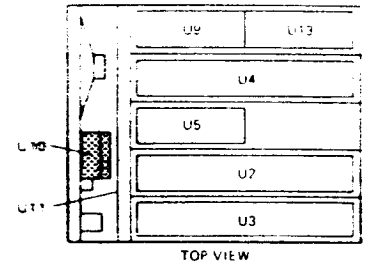
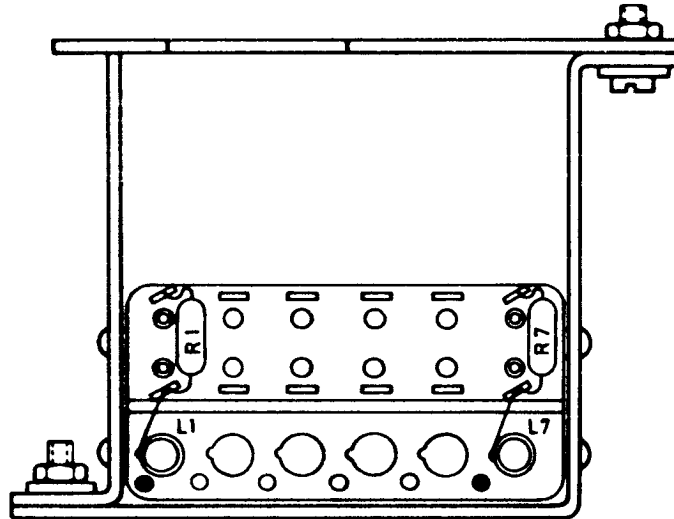

Parts List

RESISTORS

Ref.	Value	Type	Tol.%	W	Part No.
R1	1k	Carb.	±5	¼	062-023-210
R7	1k5	Carb.	±5	¼	062-023-215

CHOKES, COILS AND INDUCTORS

Ref.	Description	Part No.
L1	Netting Coil	451-782-076
L2	Netting Coil	451-782-077

Crystal Kit U10M

451-782-136

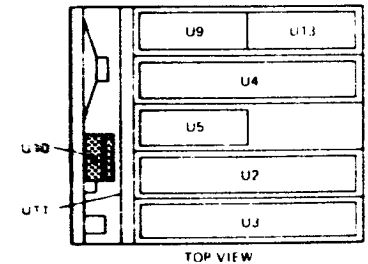
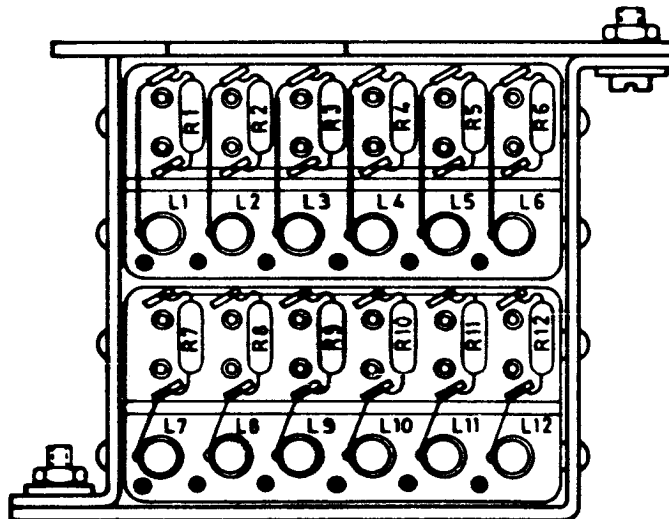

Parts List

RESISTORS

Ref.	Value	Type	Tol.%	W	Part No.
R1	1k	Carb.	±5	¼	062-023-210
R2	1k	Carb.	±5	¼	062-023-210
R3	1k	Carb.	±5	¼	062-023-210
R4	1k	Carb.	±5	¼	062-023-210
R5	1k	Carb.	±5	¼	062-023-210
R6	1k	Carb.	±5	¼	062-023-210
R7	1k5	Carb.	±5	¼	062-023-215
R8	1k5	Carb.	±5	¼	062-023-215
R9	1k5	Carb.	±5	¼	062-023-215
R10	1k5	Carb.	±5	¼	062-023-215
R11	1k5	Carb.	±5	¼	062-023-215
R12	1k5	Carb.	±5	¼	062-023-215

CHOKES, COILS AND INDUCTORS

Ref.	Description	Part No.
L1	Netting Coil	451-782-076
L2	Netting Coil	451-782-076
L3	Netting Coil	451-782-076
L4	Netting Coil	451-782-076
L5	Netting Coil	451-782-076
L6	Netting Coil	451-782-076
L7	Netting Coil	451-782-077
L8	Netting Coil	451-782-077
L9	Netting Coil	451-782-077
L10	Netting Coil	451-782-077
L11	Netting Coil	451-782-077
L12	Netting Coil	451-782-077

SWITCH

Ref.	Description	Part No.
SW1	Switch NSF Oak Model A	450-782-204

Filter and Relay Unit U12

451-782-032

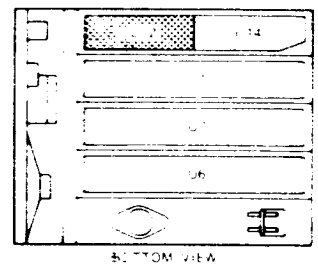
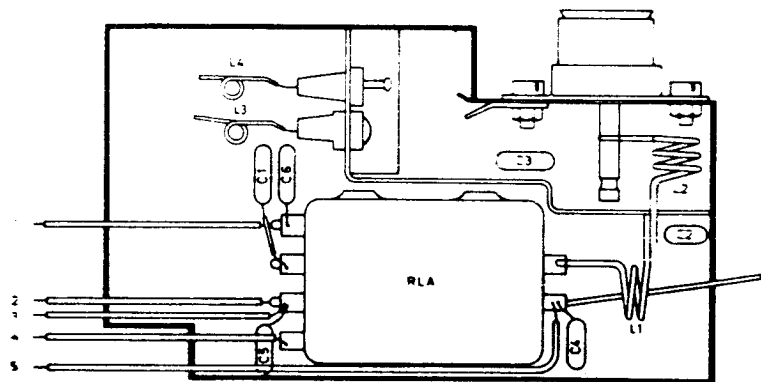

Parts List

CAPACITORS

Ref.	Value	Type	Tol. %	V.W.	Part No.
C1	10pF	C/T	±10	500	053-124-010
C2	27pF	C/D	±2%	500	051-134-027
C3	12pF	C/T	±10	500	053-124-012
C4	1000pF	C/D	±10	500	053-164-210
C5	1000pF	C/D	±10	500	053-164-210
C6	10pF	C/T	±10	500	053-124-010

CHOKES, COILS AND INDUCTORS

Ref.	Description	Part No.
L1	Harmonic Filter Coil	450-782-071
L2	Harmonic Filter Coil	450-782-072
L3	Harmonic Filter Coil	450-782-073
L4	Harmonic Filter Coil	450-782-073

RELAYS

Ref.	Description	Part No.
RLA	Haller Relay NE50962	450-782-074

Polarity Rev and S/C Protection Card U13

451-782-033 C/10

451-782-118 C/25

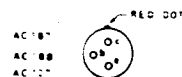
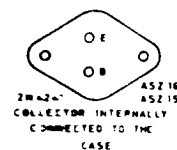
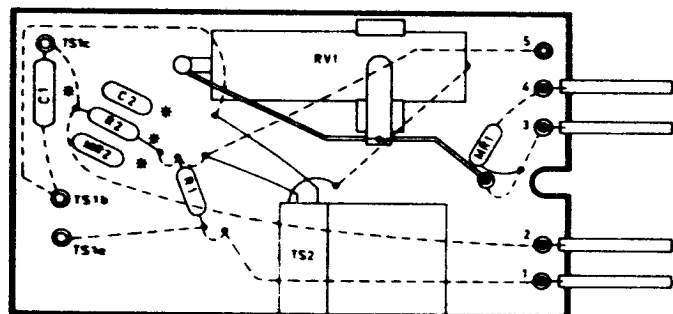

WHITE BAND INDICATES CATHODE END

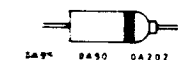
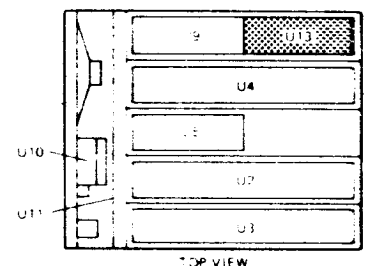

B2788 SERIES COLORED BAND INDICATES CATHODE END

Parts List

CAPACITORS

Ref.	Value	Type	Tol. %	V.W.	Part No.
*C1	4μF	E	+50 -10	40	055-237-540
*C2	0.001	C/D	20	25	218-070-310

RESISTORS

Ref.	Value	Type	Tol. %	W	Part No.
R1	2k2	Carb.	±5	¼	062-023-222
*R2	2k2	Carb.	±5	¼	062-023-222

RESISTOR VARIABLE

Ref.	Description	Part No.
RV1	Resistor Variable 250 Ohm ±10% 0.8 Watt	068-112-001

SEMICONDUCTORS

Ref.	Description	Part No.
MR1	Diode Sil. OA202	079-111-001
*MR2	Diode Sil. 1N4148 (25W only)	079-124-001
TS1	Trans. Ger. ASZ15 (10W only)	078-803-003
TS1	Trans. Ger. 2N4241 (25W only)	078-803-005
TS2	Trans. Ger. AC127 Transistor Assy	078-306-001 451-782-035

*NOTE C1 and R2 are not used in 10 Watt models only. In 25 Watt models R2 is replaced by MR2 and C2 in parallel. TS1 is mounted on a separate heatsink.

Aerial Mismatch Protection Unit U14

451-782-034 C/10

451-782-127 C/25

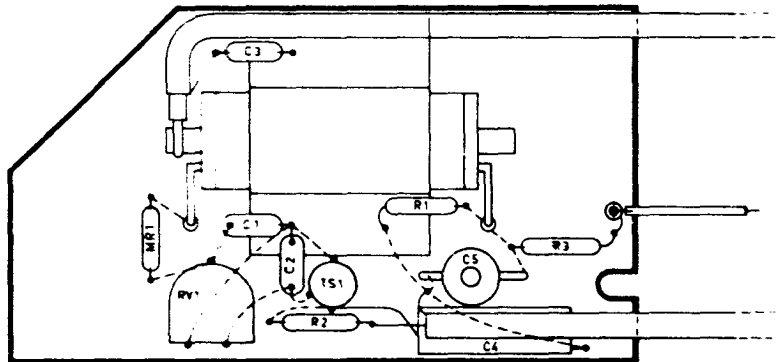
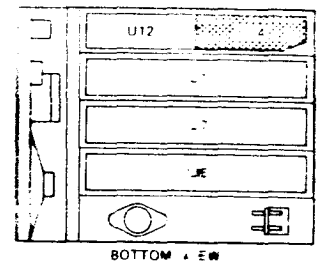

BC 107
BC 109
2W2369

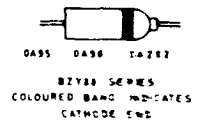

Parts List

451-782-034 C/10

CAPACITORS

Ref.	Value	Type	Tol. %	V.W.	Part No.
C1	0.001	C/D	+80 -20	25	056-173-310
C2	0.001	C/D	+80 -20	500	056-173-310
C3	0.001	C/D	+80 -20	500	056-173-310
C4	10µF	E	+50 -10	16	055-235-610
C5	22pF	Trimmer			058-011-501

RESISTORS

Ref.	Value	Type	Tol. %	W	Part No.
R1	82	Carb.	±5	¼	062-023-082
R2	100	Carb.	±5	¼	062-023-110
R3	1k5	Carb.	±5	¼	062-023-215

RESISTOR VARIABLE

Ref.	Description	Part No.
RV1	Min. Trimmer 10k ± 20% 0.1 Watt	068-072-007

SEMICONDUCTORS

Ref.	Description	Part No.
MR1	Diode Ger. OA95	079-212-002
TS1	Trans. Sil. BC107	078-101-007

451-782-127 C/25

Components as for 451-782-034,
with the following exception:

CAPACITOR

Ref.	Value	Type	Tol. %	V.W.	Part No.
C4	40µF	E	+50 -10	16	055-235-640

Miscellaneous

Parts List

Ref.	Description	Part No.
U11	Interwiring Board	451-782-012
FS1	2A (10 Watt model)	034-113-002
FS1	5A (25 Watt model)	034-113-005
FS2	2A (10 Watt model)	034-113-002
FS2	5A (25 Watt model)	034-113-005
C3	Cap. C/D 0.01 ±20% 25VW	054-173-410
XL-R1		
to	Receiver Crystals	3502-150-0555.2
XL-R6		
XL-T1		
to	Transmitter Crystals	3502-150-0556.2
XL-T6		

Microphone Assy.	451-000-003
Battery Connector Assy.	451-782-036
Mounting Tray	451-757-090
Microphone Bracket	451-757-089
Whip Aerial Assy.	451-757-016
Volume Control Knob Assy.	451-782-186
Mute Control Knob Assy.	451-782-186
Channel Selector Knob Assy.	451-782-187

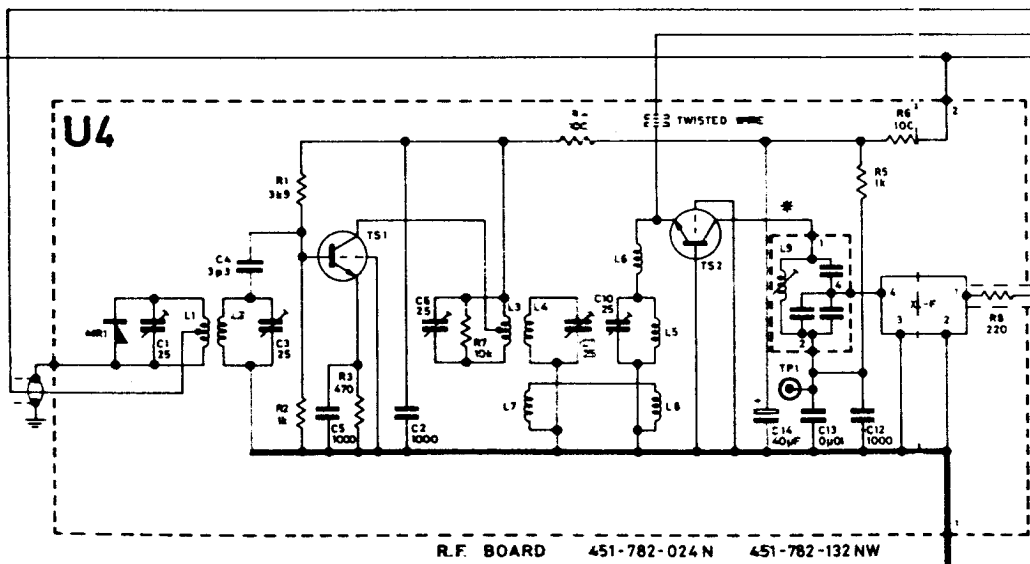
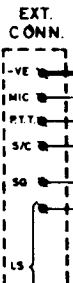
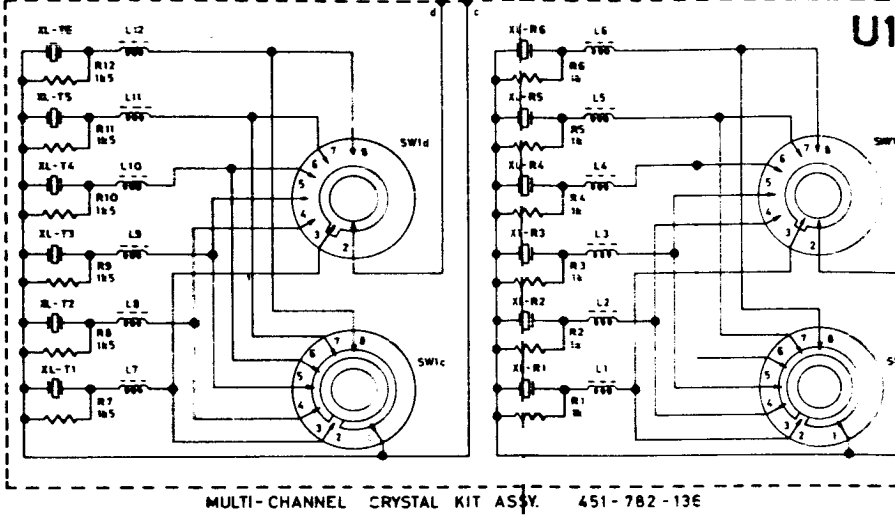
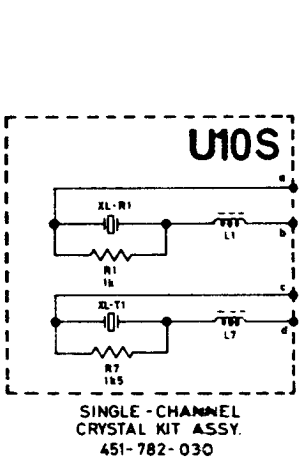
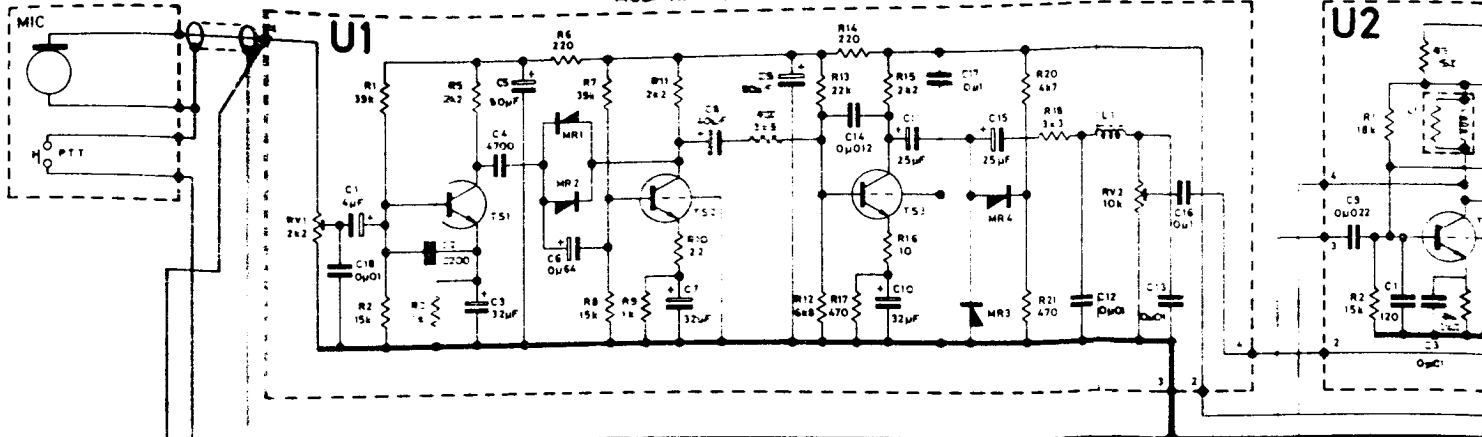

NOTE:
 PA Unit U3
 451-782-023 is installed in
 model C10
 451-782-117 is installed in
 model C25

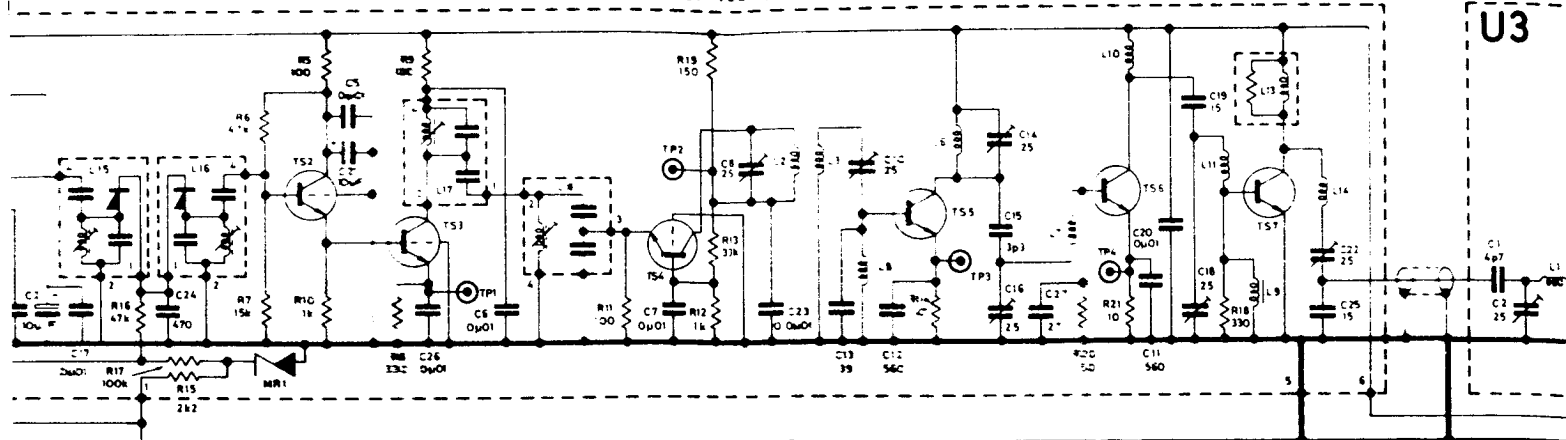

U3

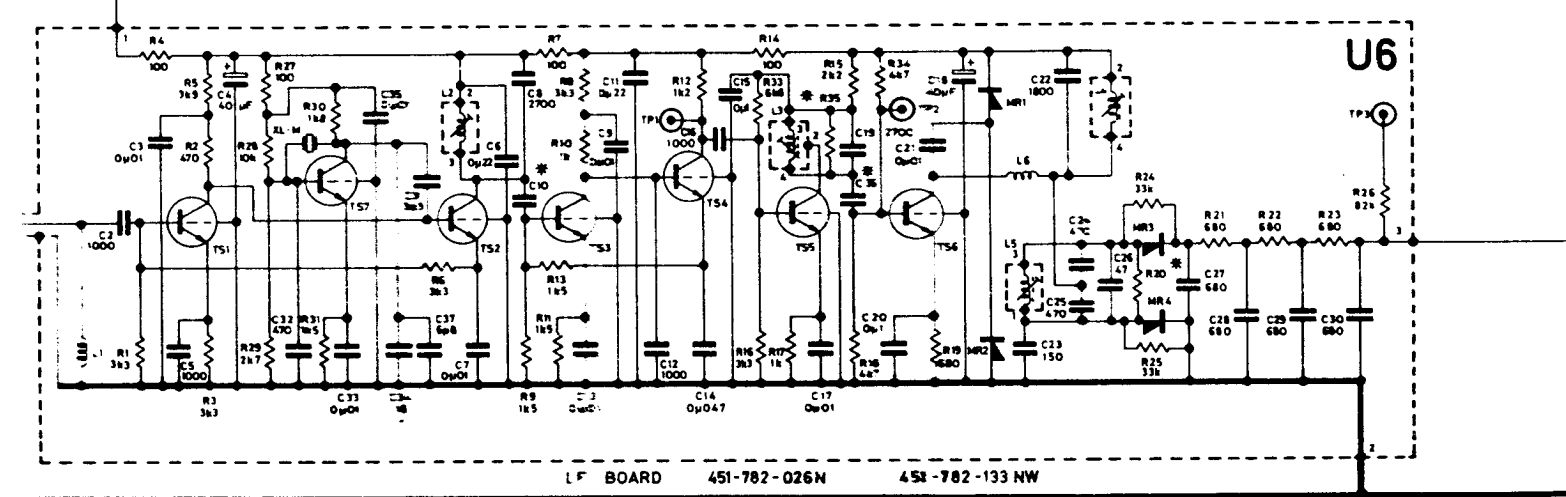
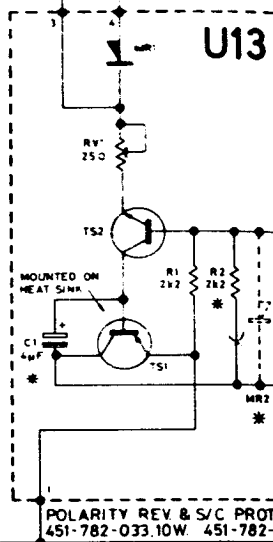
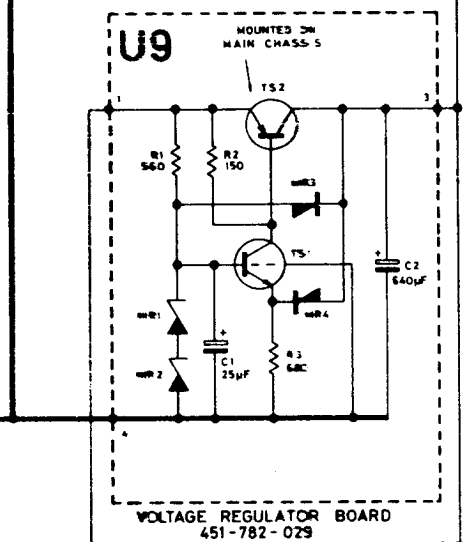
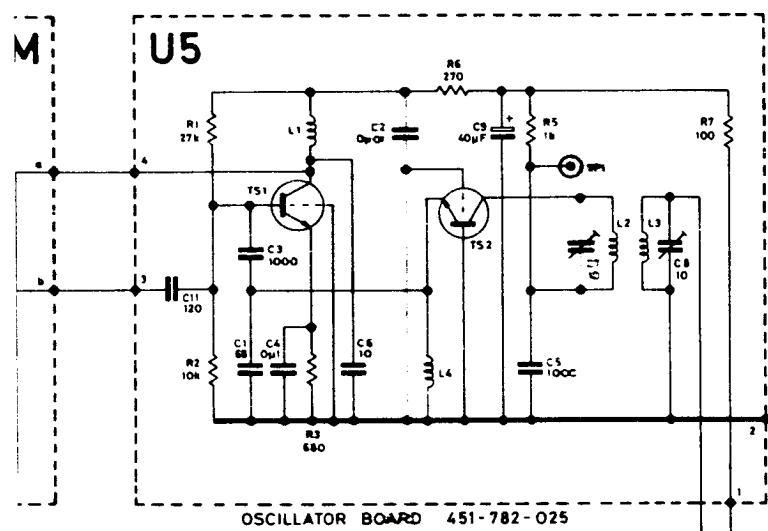

* ALTERNATIVE COMPONENTS FOR U4, U6, U7, U13 & U14

COMPONENT	U4 XL-F	U4 L9	U6 R20	U6 R35	U6 C36	U6 C10	U7 C5	U7 C19	U7 R22	U13 R2	U13 MR2	U13
NARROW BAND (N)	451-782-059	451-782-060	None	6k8	33pF	270pF	330pF	560pF	68k	Only on	Only on	Only
WIDE BAND (NW)	451-782-141	451-782-160	22k	None	1000pF	470pF	3900pF	1000pF	150k	10 Watt	25 Watt	10 W

VOLTAGE ANALYSIS (V d.c. wrt -ve earth)	U1/TS1	U1/TS2	U1/TS3	U4/TS1	U4/TS2	U5/TS1	U5/TS2	U6/TS*	U6/TS2	U6/TS3	U6/TS4	U6/TS5	U6/TS6	U6/TS7	U7/TS1
e	1.8	1.9	1.6	1.3	0	2.0	0	2.5	6.4	1.4	4.3	0.8	3.4	1.4	0.5
b	2.4	2.5	2.2	2.0	0	2.7	0	3.2	6.9	2.1	4.9	1.5	4.1	2.1	1.2
c	6.0	6.3	4.6	10.4	10.9	10.7	11.2	6.9	10.2	4.9	7.6	4.8	8.6	8.1	11.0

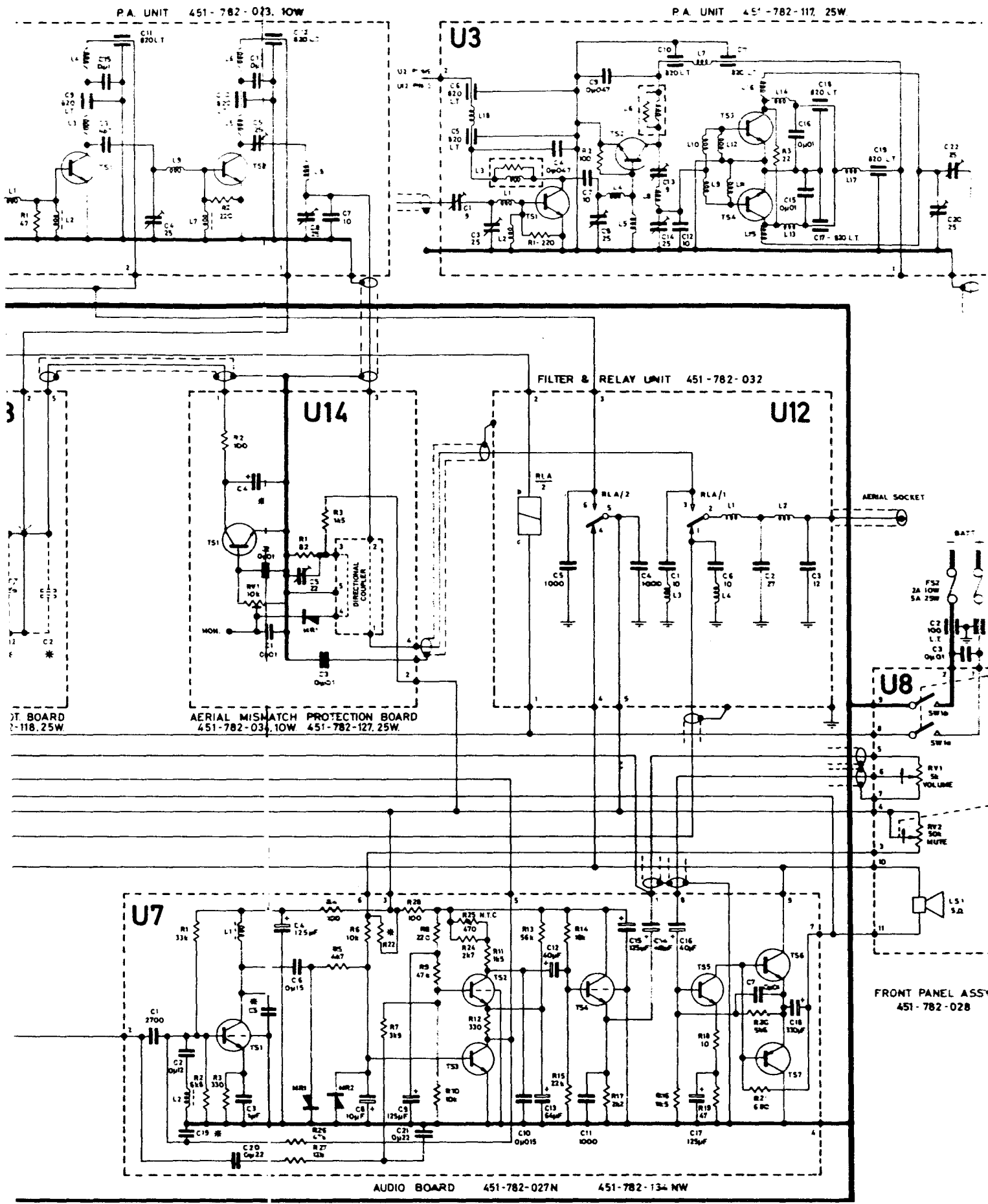

C1	U13 C2	U14 C4
on	Only on	10μF-10W
5 watt	25 Watt	40μF-25W

NOTE: All connections between units (U1 to U14) are made via the interwiring card U11.

FM1680C(148-174 MHz C BAND) CIRCUIT DIAGRAM 450-782-236

U7/TS2	U7/TS3	U7/TS4	U7/TS5	U7/TS6	U7/TS7	U9/TS1	U9/TS2
e 1.0	e 0	e 5.1	e 0.4	e 5.8	e 5.8	e 10.6	e 13.8
b 1.7	b 0.7	b 5.7	b 1.1	b 5.8	b 5.8	b 11.4	b 13.3
c 6.0	c 0.05	c 10.8	c 5.8	c 11.4	c 0	c 13.3	c 11.4

- c. Multi-channel. — Accomplish steps 1 through 8 for a mid channel, then check the remaining channels for optimized alignment. — If necessary, optimization may be accomplished by re-adjustment of the twisted wire capacitor.

2.1.7 Page 24

Component Layout, Exciter Board U2 (451-782-021)

Component "C11" should read "C21"

2.2 CIRCUIT CORRECTION

Circuit Diagram 450-782-236 requires the following corrections:

C BAND

U5 (Oscillator Board 451-782-025)

Add: C10 (6p8) in parallel with C6

2.3 CIRCUIT CHANGES

Circuit Diagram 450-782-236 requires the following changes

C BAND

U3 (PA Unit 451-782-023)

Add: C16 (39p) between emitter and base of TS2

U3 (PA Unit 451-782-117)

Add: C23 (63p) between emitter and base of TS2

2.4 CORRECTED PART IDENTIFICATION

Part identification requires the following corrections:

A BAND

PA Unit U3 (451-782-130) Page 24

C5 22pF C/P ±2% 500V 051-124-022

Filter and Relay Unit U12 (451-782-098) Page 31

Add: Aerial Socket, Belling Lee, 036-002-001

2.1.3 Page 18

Figure 2: Change "455kHz GEN" to read
"10.7MHz MARKER"

IF Alignment (U6): Delete step 2.

2.1.4 Page 39

Under Test Equipment, delete:

"(e) 455kHz Generator - Philips PM5300"

2.1.5 Page 40

Figure 5: Change "455kHz GEN" to read
"10.7MHz MARKER"

IF Alignment (U6): Delete step 2.

Oscillator Alignment (U5): Delete entire procedure and substitute the following:

1. Single Channel. Set 5C7 and 5C8 to maximum capacity positions.
2. Ascertain that the minimum spacing between L2 and L3 is 0.4 inch.
3. Ascertain that the correct crystal is in the receiver crystal socket.
4. Connect the AV08 (10 Vdc range) between 5TP1 and the 11.4V +ve rail.
5. Adjust the netting coil slug for maximum voltage reading.
6. Tune 5C7 for minimum voltage reading.
7. Connect AV08 (2.5 Vdc range) -ve lead to 4TP1 and the +ve lead to 4R5 (top loop).
8. Tune 5C8 and repeak 5C7 for maximum output. If the level is outside the range 0.7V to 1.5V, then adjust the turns on the twisted wire capacitor, repeaking 5C7 and 5C8 after each adjustment.

NOTE: Care should be taken to keep the twisted wire capacitor vertical and at a minimum distance of 0.2 inch from the shield to minimize changes in capacitance if the wire shifts slightly. The wire length should be such that the upper end is about 0.2 inch below the top of the shield.

C BAND

Exciter Board U2 (451-782-022) Page 44

C4 22pF C/P ±2% 500VW 051-124-022

PA Unit U3 (451-782-023) Page 45

Add:

C16 39pF C/D NPO ±5% 630VW 052-126-039

PA Unit U3 (451-782-117) Page 46

Add:

C23 68pF ±10% 350VW 350VW 053-132-068

Oscillator Board U5 (451-782-025) Page 48

C10 6p8 C/D ±0p25 051 051-124-968

Audio Board U7 (451-782-027 and 451-782-134) Page 50

C21 0μ22 P/e ±10% 100VW 053-457-422

2.5 NEW REPLACEMENT PARTS

Identification of the following parts differs from the corresponding original parts. However, when these parts are replaced they should be identified as follows to assume availability and facilitate supply. Current FM1680 equipment already contains parts as identified herein.

A BAND

Mod. Ampl. Board U1 (451-782-021) Page 21

C8 47μF Electro +50-10% 25VW 2222-015-16479

PA Unit U3 (451-782-130) Page 24

C9 10pF C/D NPO ±5% 630V 052-126-010

RF Board U4 (451-782-045 and 451-782-135) Page 25

C14 47μF Electro +50-10% 25VW 2222-015-16479

Oscillator Board U5 (451-782-096) Page 26

C9 47μF Electro +50-10% 25VW 2222-015-16479

IF Board U6 (451-782-026 and 451-782-133) Page 27

C4 } 47μF Electro +50-10% 25VW 2222-015-16479
C18 }

Audio Board U7 (451-782-027 and 451-782-134) Page 28

C4 }
C9 } 150μF Electro +50-10% 16VW 2222-016-15151
C15 }
C17 }

C12)					
C14)	47 μ F	Electro	+50-10%	25VW	2222-015-16479
C16)					

C13	68 μ F	Electro	+50-10%	16VW	055-235-668
-----	------------	---------	---------	------	-------------

Voltage Regulator Board U9 (451-782-029) Page 29

C2	680 μ F	Electro	+50-10%	26VW	2222-017-15681
----	-------------	---------	---------	------	----------------

Polarity Rev. S/C Protection Card U13 (451-782-033 and 451-782-118) Page 31

TS2	Transistor, Ge	AC187	078-317-001
-----	----------------	-------	-------------

Miscellaneous Page 32

U11 Interwiring Board, 451-782-237

Microphone Assy. 451-000-012

C BAND

Mod. Ampl. Board U1 (451-782-021) Page 43

C8	47 μ F	Electro	+50-10%	25VW	2222-015-16479
----	------------	---------	---------	------	----------------

PA Unit U3 (451-782-023) Page 45

C7	10pF	C/D NPO	\pm 5%	630VW	052-126-010
----	------	---------	----------	-------	-------------

PA Unit U3 (451-782-117) Page 46

C7)	10pF	C/D NPO	\pm 5%	630VW	052-126-010
C12)					

RF Board U4 (451-782-024 and 451-782-132) Page 47

C14	47 μ F	Electro	+50-10%	25VW	2222-015-16479
-----	------------	---------	---------	------	----------------

Oscillator Board U5 (451-782-025) Page 48

C9	47 μ F	Electro	+50-10%	25VW	2222-015-16479
----	------------	---------	---------	------	----------------

IF Board U6 (451-782-026 and 451-782-133) Page 49

C4)	47 μ F	Electro	+50-10%	25VW	2222-015-16479
C18)					

Audio Board U7 (451-782-027 and 451-782-134) Page 50

C4)	150 μ F	Electro	+50-10%	16VW	2222-016-15151
C9)					
C15)					
C17)					

C12)	47 μ F	Electro	+50-10%	25VW	2222-015-16479
C14)					
C16)					

C13	68 μ F	Electro	+50-10%	16VW	055-235-668
-----	------------	---------	---------	------	-------------

Voltage Regulator Board U9 (451-782-029) Page 51

C2 680 μ F Electro +50-10% 16VW 2222-017-15681

Polarity Rev. and S/C Protection Card U13 (451-782-033 and
451-782-118) Page 53

TS2 Transistor Ge AC187 078-317-001

Miscellaneous

U11 Interwiring Board, 451-782-237

Microphone Assy., 451-000-012

3.4 U7 AUDIO CARD WITH INCREASED OUTPUT

3.4.1 PURPOSE

Installation of a new type audio amplifier card employing an integrated circuit output stage to provide a 3-watt audio output on all models at the facilities socket (SK1), whilst limiting the audio output of the internal loudspeaker to the present handling capacity of 2 watts.

3.4.2 PARTS REQUIRED

CCT REF	PART NO.	NOMENCLATURE	QTY
U7	451-782-243	Assy, Audio U7/N	1
	or		
U7	451-782-248	Assy, Audio U7/NW	1
R1	062-053-910	Resistor, WW, 1 ohm 10% 5W	1

3.4.3 PROCEDURE

3.4.3.1 Facility Socket Fitted

- a. Unsolder all U7 Audio Card (451-782-027/134) connections from U11 Interconnection Board.
- b. Remove U7 Audio Card 451-782-027/134, complete with leads, from honeycomb.
- c. Place new U7 Audio Card 451-782-243/248 into position in the honeycomb and loose fit all screws.

NOTE: U7 fixing screws to be tightened in the following order.

- (1) Heatsink in honeycomb
 - (2) Heatsink to IC1
 - (3) U7 Card to honeycomb
- d. Remove lead connecting socket SK1 pin 1, with loudspeaker.
 - e. Remove leads connecting socket SK1 pin 5 with loudspeaker and U11 interconnection board.
 - f. Remove riveted terminal LS10 on U11 board (see figure 3-5) and increase hole dimension to 0.120".

- h. Solder white wire from U7 card TP1 to U11/U7-1.
- j. Solder white wire from U7 card TP2 to U11/U7-2.
- k. Solder white wire from U7 card TP3 to U11/U7-3.
- l. Solder white wire from U7 card TP4 to U11/U7-4.
- m. Solder white wire from U7 card TP5 to U11/U7-5.
- n. Solder white wire from U7 card TP6 to U11/U7-6.
- p. Solder white wire from U7 card TP7 to U11/U7-7.
- q. Solder white wire from U7 card TP8 to U11/U7-8.
- r. Solder blue wire from U7 card TP11 to U11/U12-3.
- s. Solder red wire from U7 card TP12 to U11/U12-1.
- t. Route grey wire from U7 card TP13 through hole made in step e, cut back to suitable length and solder to loudspeaker terminal 10.
- u. Use length of grey wire remaining from step s. to connect loudspeaker terminal 10 to socket SK1 pin 1.
- v. Solder 1 ohm wire wound resistor (R1) between socket SK1 pin 5 and loudspeaker terminal 11.

3.4.3.2 Facility Socket Not Fitted

In the event that the external facilities socket SK1 has not been incorporated proceed as above with the following amendments:

- (1) Delete 3.4.3.1 step d. and substitute:
 - d. Remove leads connecting loudspeaker and U11 interconnection board.
- (2) Delete 3.4.3.1 steps u. through v. and substitute:
 - u. Refer to figure 3-7 and replace link with 1 ohm wire wound resistor R1.
 - v. Use 2½" length of white wire to connect U11 External Connection LS1 to loudspeaker terminal 11.

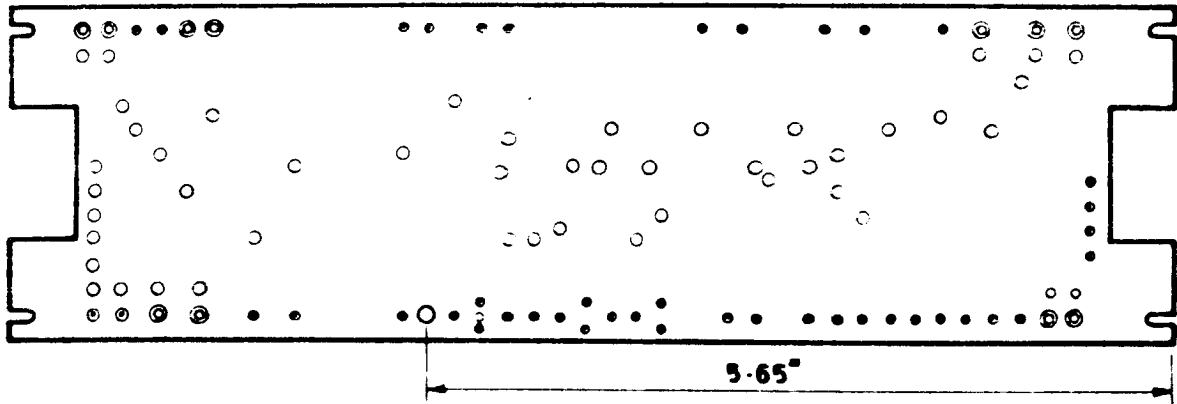

Figure 3-5 Location of terminal LS10

- g. Refer to figure 3-6 for routing of the following connections of U7 Audio Card 451-782-243/248.

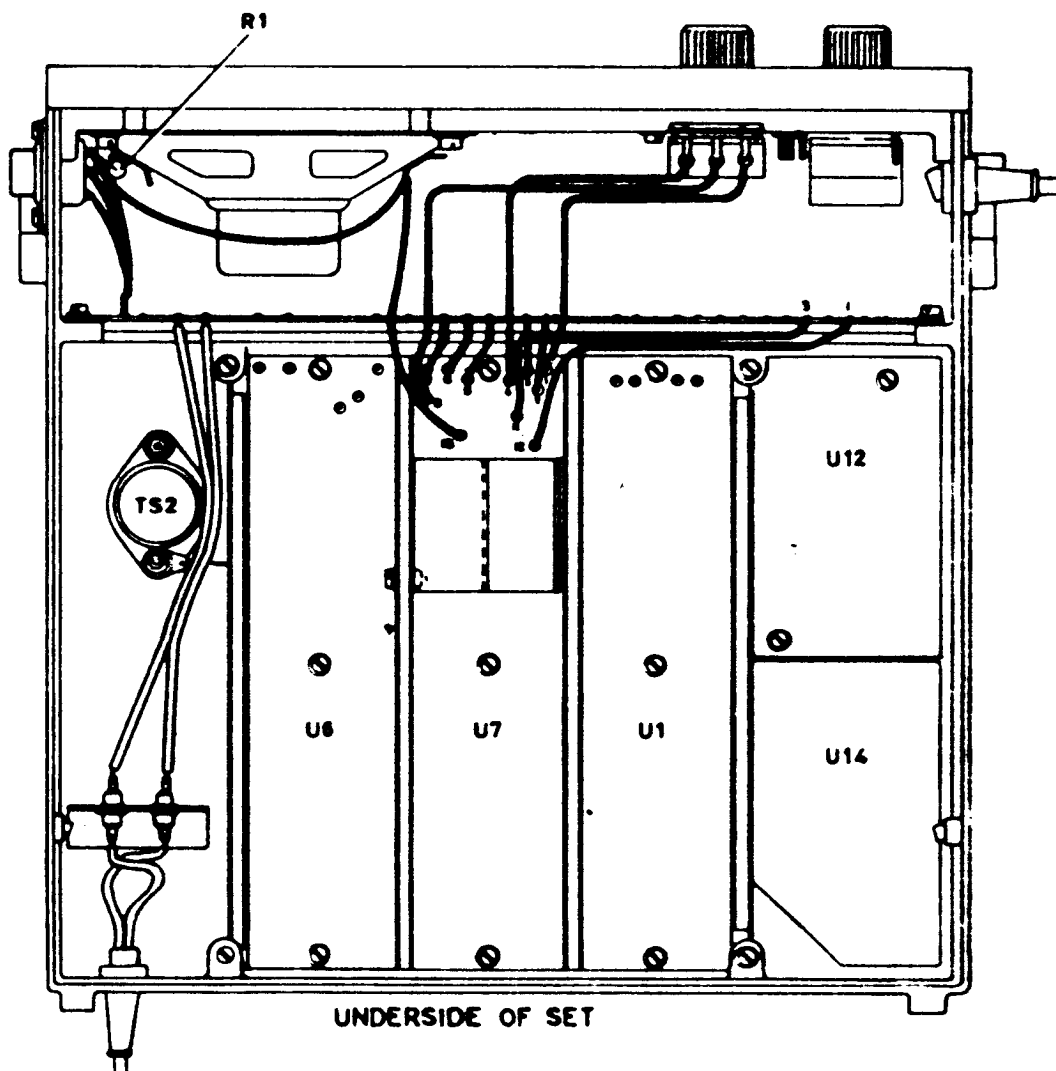

Figure 3-6 U7 Audio Card Wiring

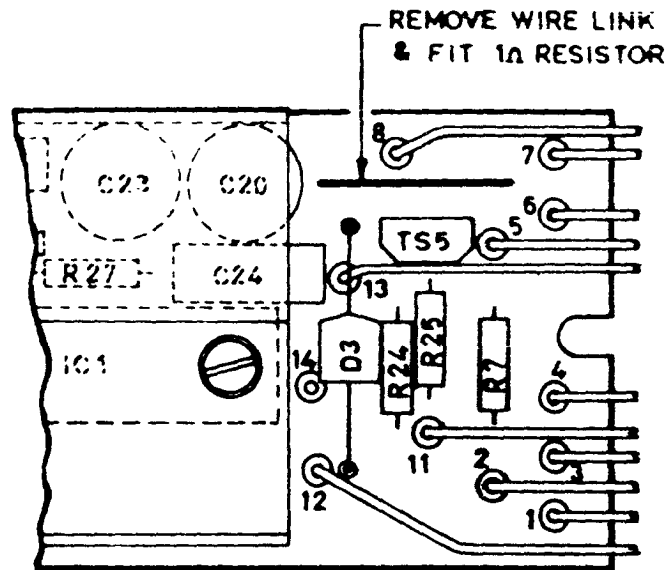

Figure 3-7 U7 Card Link/Resistor Location

3.4.4 TEST PROCEDURE

- a. Amend the handbook receiver alignment and test procedure section Audio Output and Distortion to read as follows:
 - (1) Set the signal generator to 1 kHz modulation with 3.3 kHz (N) on 10 kHz (NW) deviation.
 - (2) Adjust the receiver input to 5 μ V and set the Volume Control to give an output of 3 watts (3.9V across a 5 Ω dummy load).
 - (3) Distortion must not exceed 10%.

3.5 INSTABILITY REDUCTION

This modification is incorporated as standard on current equipment and should only be incorporated on older sets where instability necessitates embodiment.

3.5.1 PURPOSE

Reduction of transmitter instability and spurious radiation on FM1680C equipment.

3.5.2 PARTS REQUIRED

ITEM	CCT REF	PART NO.	NOMENCLATURE	QTY
A	U2/R22	062-023-247	Resistor, Carb. 4k7 5% 0.25w	1
B	U2/R23	062-023-210	Resistor, Carb. 1k 5% 0.25w	1
C	U2/R4	062-023-218	Resistor, Carb. 1k8 5% 0.25w	1
D	U2/R6	062-023-333	Resistor, Carb. 33k 5% 0.25w	1
E	U14/C3	054-403-001	Cap. F/Thru 1n +80-20% 500V	1
F		036-800-035	Lug, Solder .202	1
G	U11/C4	053-177-222	Cap. Cer. NP0 2n2 10% 100V	1
H	U11/C5	053-177-222	Cap. Cer. NP0 2n2 10% 100V	1
J	U11/C6	053-177-222	Cap. Cer. NP0 2n2 10% 100V	1
K		006-106-508	Screw, 6BA Ch x 0.5	1
L		036-800-003	Lug, Solder 0.123	1
M		014-260-104	Washer, lock 0.123 S Coil	1
N		013-260-501	Nut, 6BA	1
P		905-506-902	Sleeving, PTFE AWG 18 UTW	2"

3.5.3 PROCEDURE

a. Exciter Card U2 (451-782-022)

- (1) Remove Exciter Card U2 from honeycomb.
- (2) Cut copper track between junction R2/C9 and L15 pin 4 as shown in figure 3-8.

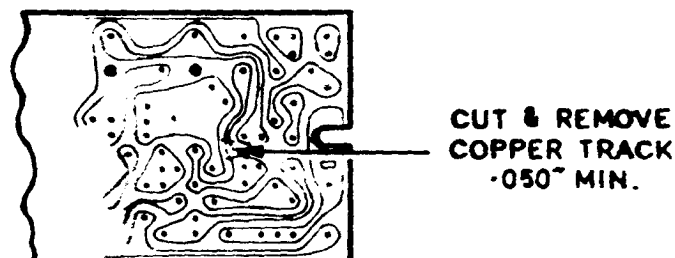

Figure 3-8 Underside Copper Track Cut-away

- (3) Remove resistor R6 (47k Ω) from its standing position adjacent to C21 and fit resistor 33k Ω (item D) to a standing position adjacent to R7.
- (4) Remove coil L10 from its standing position adjacent to C21 and refit in a standing position adjacent to TS6.
- (5) Remove coil L13 from its standing position adjacent to L11 and refit in a standing position adjacent to TS7.
- (6) Solder a 4.7k Ω resistor (item A) between terminal TP4 and L15 pin 4 on copper track side of board, covering any exposed resistor lead with PTFE sleeving (item P). Circuit designation R22.
- (7) Solder a 1k Ω resistor (item B) between terminal TP2 and junction of C8/L2/TS4, covering any exposed resistor lead with PTFE sleeving (item P). Circuit designation R23.
- (8) Remove resistor R4 (2.2k Ω) and replace with resistor 1.8k Ω (item C).
- (9) Refit U2 Exciter Card to honeycomb.

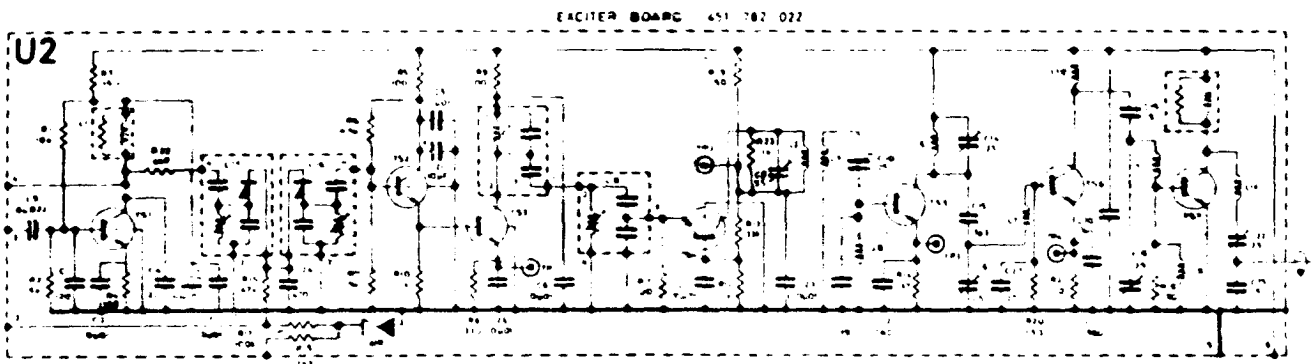

Figure 3-9 Exciter Board U2 Modified Circuit

b. Aerial Mismatch Protection Unit U14 (451-782-034/127)

- (1) Remove Protection Unit U14 from the honeycomb.
- (2) Remove 0.01 μ F ceramic disc capacitor C3 and replace with 1nF feedthrough capacitor (item E) and .202 solder lug (item F) as shown in figure 3-10. Retain C3 circuit designation.

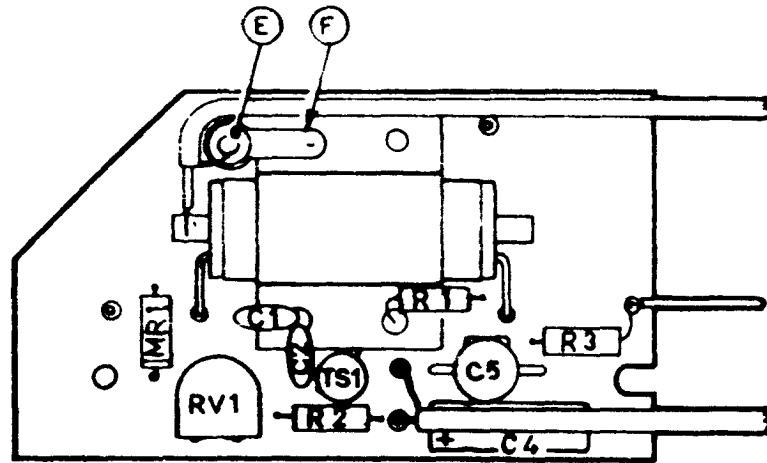

Figure 3-10 U14 Protection Unit Layout

(3) Refit Protection Unit U14 to honeycomb.

c. Interconnection Card U11.

(1) Remove top right hand card $\frac{1}{4}$ inch cheesehead retaining screw and discard.

(2) Re-secure top right hand corner of card using $\frac{1}{2}$ inch cheesehead 6BA screw (item K).

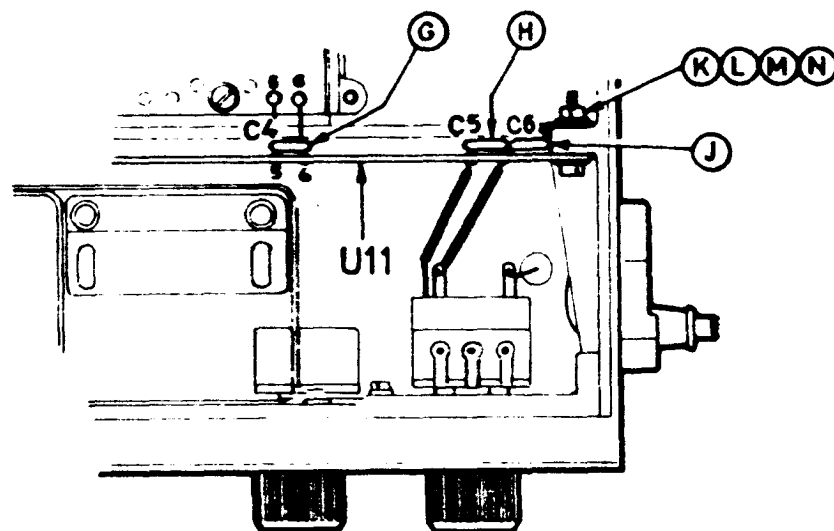

Figure 3-11 By-pass Capacitor Location

(3) Fit 0.123 solder lug, 0.123 coil lock washer, and nut (items L, M, & N) to screw fitted in step (2).

- (4) Solder 2n2 ceramic plate (item G) between U11 pins U11/E2-5 and U11/E2-6, circuit reference designation C4.
- (5) Solder 2n2 ceramic plate (item H) between U11 pins U11/E3-8 and U11/E3-9, circuit reference designation C5.
- (6) Solder 2n2 ceramic plate capacitor (item J) between U11/E3-9 and the solder tag fitted in step (3).

3.5.4 TEST PROCEDURE

The test procedure detailed in the handbook Transmitter Alignment and Test Procedure is unaltered by this modification. It should be noted, however, that the transmitter distortion after de-emphasis is commonly not greater than 3%, the required drive of 2.3mA (meter reading) at TP1 is easily obtained, and the pulling of the oscillator with tuning of U1/L15 is eliminated.

3.6 FREQUENCY RANGE 137-142 MHz

3.6.1 PURPOSE

To enable FM16800/25N Six Channel to operate within the frequency range of 137-142 MHz.

3.6.2 PARTS REQUIRED

ITEM	PART NO.	NOMENCLATURE	QTY
A	451-782-246	Assy, Tx 6 channel 137-142 MHz	1
B	014-260-101	Washer, Flat 0.123 Large	3
C	014-260-105	Washer, Lock 0.123 Int.	3
D	051-096-947	Capacitor, Ceramic Plate 4p7 ±.25p 63V	2
E	052-214-015	Capacitor, Ceramic Tub, 15p ±5% 500V	2

3.6.3 PROCEDURE

a. Front Panel

- (1) Remove top and bottom covers and retain parts.
- (2) Unsolder the four leads from channel select switch SW1 that pass through interconnection card U11.
- (3) Remove knob from channel select switch SW1 and retain parts.
- (4) Remove front panel and retain parts.
- (5) Remove channel crystal assembly U10 from front panel and retain parts.

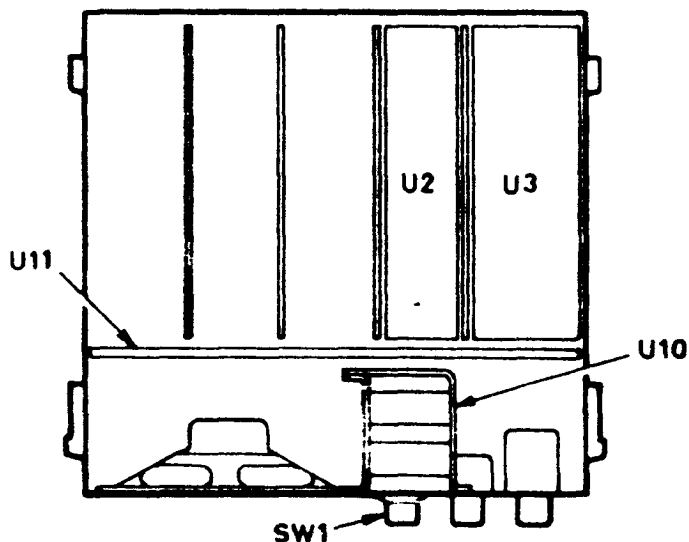

Figure 3-12 Top view with cover removed

b. Channel Crystal Assy.

- (1) Unsolder transmit channel crystal assembly leads from the channel select switch SW1 rear wafer.
- (2) Remove transmit channel crystal assembly.
- (3) Fit new transmit channel crystal assy. (item A) into channel crystal assembly.
- (4) Solder transmit channel crystal assy. leads to switch SW1 rear wafer as shown in figure 3-13.

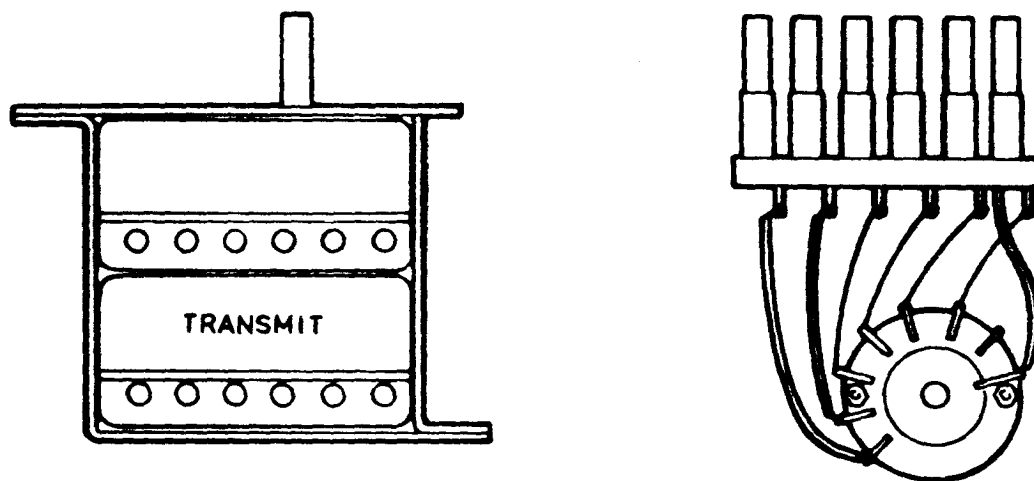

Figure 3-13 Transmit Channel Crystal Assy Connections

- (5) Refit channel crystal assy. U10 to front panel using screws retained from step a. (5), and washers items B and C.

c. Front Panel.

- (1) Refit front panel with screws retained in step a. (4).
- (2) Refit knob removed in step a. (3) to switch SW1, aligning "1" with front panel mark with switch in full anticlock position viewed from front.

d. Exciter Card U2.

- (1) Unsolder leads 1, 2, 5, and 6 from interconnection card U11.
- (2) Unsolder output lead.

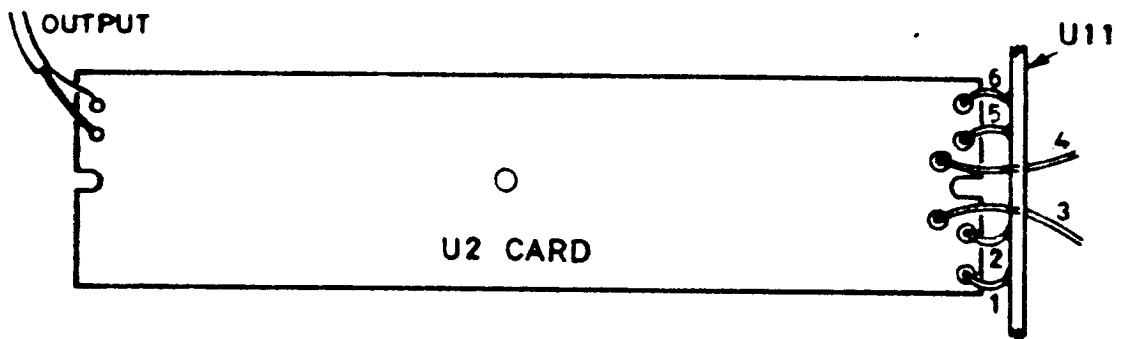

Figure 3-14 Exciter Card U2 Connections

- (3) Remove exciter card from honeycomb withdrawing leads 3 and 4 through U11, and retain parts.
- (4) Solder two 4pf Ceramic plate capacitors (item D) to track side of card as shown in figure 3-15.

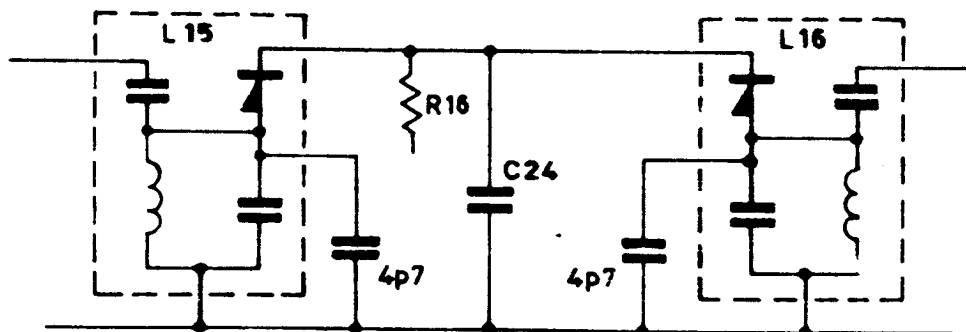
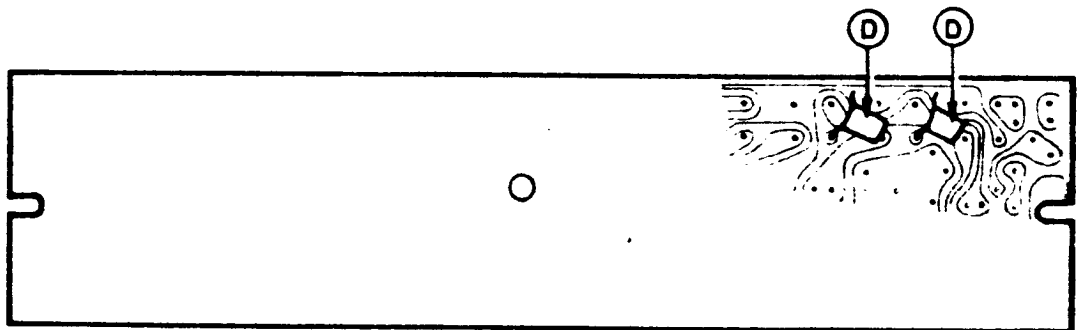

Figure 3-15 U2 Card Additional Capacitor Locations and Modified Circuit

- (5) Refit exciter card to honeycomb using parts retained in step (3).
- (6) Pass leads 3 and 4 through U11.
- (7) Resolder leads 1, 2, 5, and 6 to U11.
- (8) Resolder output lead.

e. PA Unit U3.

- (1) Solder two 15 pF ceramic tubular capacitors (item E) to PA unit U3 as shown in figure 3-16.

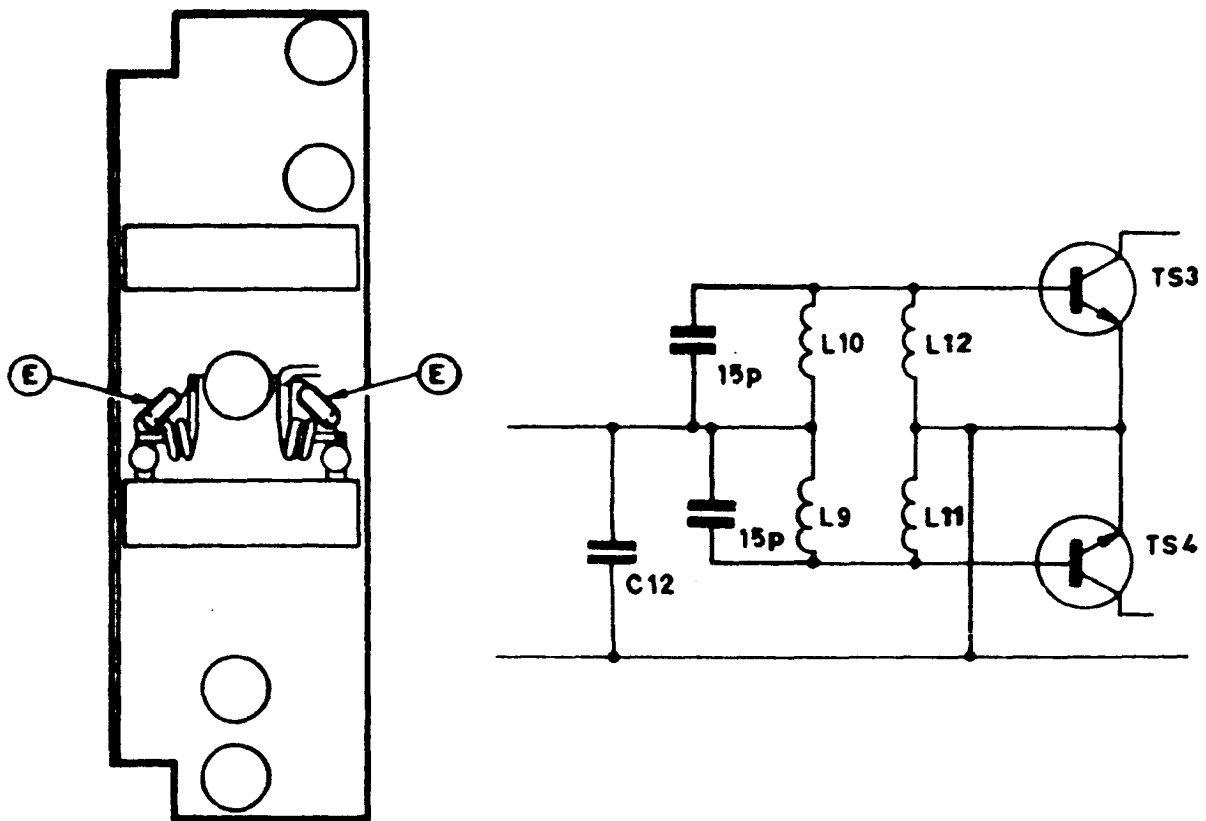

Figure 3-16 U3 Card Additional Capacitor Locations and Modified Circuit

f. Front Panel.

- (1) Resolder four leads removed in step a. (2) to channel select switch SW1 as shown in figure 3-17.

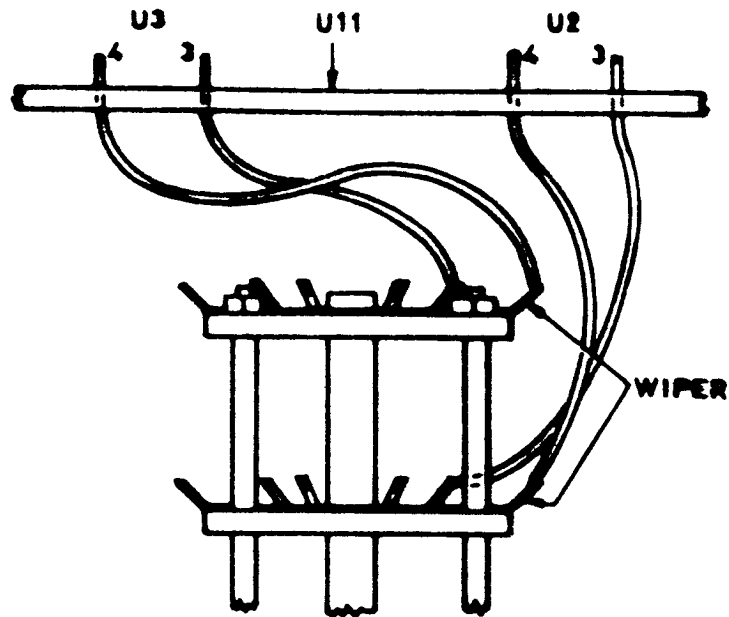

Figure 3-17 U2/U3 Connections to Switch SW1

- (2) Fit crystals for required frequencies.
- (3) Refit covers removed in step a. (1) after testing completed.

3.6.4 TEST PROCEDURE

The test procedure detailed in the handbook Transmitter Alignment and Test Procedure for power and bandwidth is unaltered by this modification, and transmitter netting should be carried out in accordance with the standard handbook procedure.

K4XL's **BAMA**

This manual is provided **FREE OF CHARGE** from the “BoatAnchor Manual Archive” as a service to the Boatanchor community.

It was uploaded by someone who wanted to help you repair and maintain your equipment.

If you paid anyone other than BAMA for this manual, you paid someone who is making a profit from the free labor of others without asking their permission.

You may pass on copies of this manual to anyone who needs it. But do it without charge.

Thousands of files are available without charge from BAMA. Visit us at <http://bama.sbc.edu>